

**BA11-K mounting box
manual**

1st Edition, September 1974
2nd Edition, February 1975

Copyright © 1975 by Digital Equipment Corporation

The material in this manual is for informational purposes and is subject to change without notice.

Digital Equipment Corporation assumes no responsibility for any errors which may appear in this manual.

Printed in U.S.A.

The following are trademarks of Digital Equipment Corporation, Maynard, Massachusetts:

DEC
FLIP CHIP
DIGITAL
UNIBUS

PDP
FOCAL
COMPUTER LAB

CONTENTS

	Page
CHAPTER 1	BA11-K CHARACTERISTICS AND SPECIFICATIONS
1.1	GENERAL 1-1
1.2	PHYSICAL CHARACTERISTICS 1-1
1.2.1	BA11-K Characteristics 1-1
1.2.2	H765 Power System 1-2
1.3	ELECTRICAL SPECIFICATIONS 1-4
1.3.1	BA11-KE, BA11-KF Input Power Electrical Specifications 1-4
1.3.2	BA11-K Output Power Specifications 1-6
1.3.3	Power Up, Power Down Characteristics 1-7
CHAPTER 2	SYSTEM UNITS, OPTIONS, HARNESSSES, AND INSTALLATION INFORMATION
2.1	GENERAL 2-1
2.1.1	Introduction to System Units 2-1
2.1.2	BA11-K System Unit Configuration 2-3
2.1.3	Unibus Pin Assignments 2-4
2.1.4	System Unit Installation 2-4
2.2	OPTION CONFIGURATIONS 2-6
2.3	COMPUTER OPTION AND MAIN POWER WIRE HARNESSSES 2-10
2.4	POWER DISTRIBUTION WIRE COLOR CODING 2-10
2.5	UNIBUS AND COMMUNICATION CABLE ROUTING 2-11
2.6	CABINET AND SLIDE MOUNTING SPECIFICATIONS 2-12
CHAPTER 3	H765 POWER SYSTEM
3.1	INTRODUCTION 3-1
3.2	MECHANICAL DESCRIPTION 3-1
3.2.1	H744, H745, and H754 Regulators 3-1
3.2.2	5411086 Regulator 3-1
3.2.3	7010014 Transformer Assembly 3-1
3.2.4	7009811-1, -2 AC Input Box 3-1
3.2.5	1211714 Box Fan 3-1
3.2.6	5410864 Power Distribution Board 3-1
3.3	SYSTEM FUNCTIONAL DESCRIPTION 3-2
3.4	SYSTEM CIRCUIT DESCRIPTION 3-2
3.4.1	AC Input Box 3-2
3.4.2	Transformer Assembly 3-2
3.4.3	5411086 Regulator 3-7
3.4.4	H744 +5 V Regulator 3-9
3.4.5	H745 -15 V Regulator 3-12
3.4.6	H754 +20, -5 V Regulator 3-12
3.4.7	Power Distribution Board 3-14
CHAPTER 4	MAINTENANCE
4.1	MAINTENANCE EQUIPMENT REQUIRED 4-1
4.2	PREVENTIVE MAINTENANCE 4-2
4.2.1	General 4-2
4.2.2	Physical Checks 4-2

CONTENTS (Cont)

		Page
4.3	MAINTENANCE PROCEDURE	4-2
4.3.1	H765 Power System Fault Isolation	4-2
4.3.2	Voltage Regulator Checks and Adjustments	4-5
4.3.3	Voltage Regulator Troubleshooting	4-5
4.3.4	Regulator Bench Test Procedures (H744, H745, and H754)	4-6
4.3.4.1	Initial Tests	4-6
4.3.4.2	Output Short Circuit Tests	4-6
4.3.4.3	Testing a "Dead" Regulator	4-6
4.3.4.4	Testing a Voltage Regulator After Repairs	4-7
4.4	H765 POWER SYSTEM SUBASSEMBLY REMOVAL PROCEDURE	4-8
4.4.1	Introduction	4-8
4.4.2	H765 Power System Access Procedure (Figure 4-4)	4-8
4.4.3	H744, H745, and H754 Regulator Removal (Figure 4-5)	4-10
4.4.4	AC Input Box and 5411086 Regulator Removal	4-11
4.4.5	Fan Removal	4-12
4.4.6	Transformer Assembly Removal	4-13
4.4.7	Power Distribution Board Removal	4-16
4.4.8	Regulator Installation	4-16
CHAPTER 5	UNPACKING AND INSTALLATION	
5.1	INTRODUCTION	5-1
5.2	UNPACKING	5-1
5.3	INSTALLATION IN A CABINET	5-1
5.4	AC POWER SUPPLY CONNECTION	5-1
5.4.1	Connecting to 115 Vac or 230 Vac	5-1
5.4.2	Quality of AC Power Source	5-1
5.5	REMOTE POWER CONTROL	5-3
5.6	INSTALLATION CERTIFICATION	5-3

ILLUSTRATIONS

Figure No.	Title	Page
1-1	BA11-K Mounting Box (Top Covers Removed)	1-1
1-2	BA11K Physical Layout	1-2
1-3	Physical Layout of H765 Power Supply	1-6
2-1	Standard Unibus Connection	2-1
2-2	BB11 Single System Unit	2-2
2-3	System Unit Configurations	2-3
2-4	BA11-K with Double System Unit (Wire Wrap Side)	2-5
2-5	Cable Routing	2-11
2-6	BA11-K and CPU Cabinet Mounting Specification	2-12
2-7	Accuride Slide Mounting Specification	2-13
2-8	Chassis-Trak Slide Mounting Specification	2-13
3-1	Power System Functional Block Diagram	3-3
3-2	Power System Detailed Diagram	3-4

ILLUSTRATIONS (Cont)

Figure No.	Title	Page
3-3	115 V Power Configuration	3-5
3-4	230 V Power Configuration	3-5
3-5	Power Control Simplified Diagram	3-5
3-6	5411086 Block Diagram	3-6
3-7	5411086 Regulator Waveforms	3-7
3-8	5411086 Power Up and Power Down	3-9
3-9	Voltage Regulator E1, Simplified Diagram	3-10
3-10	H744 Regulator Waveforms	3-11
3-11	Power Distribution Board	3-13
3-12	H744 Connection Diagram	3-14
4-1	H765 Fault Isolation Flowchart	4-3
4-2	Regulator Adjustments	4-4
4-3	Typical Voltage Regulator Output Waveforms	4-7
4-4	H765 Power System Access (Maintenance Position)	4-9
4-5	Regulator Removal	4-10
4-6	H765 Power System	4-11
4-7	Fan Removal	4-12
4-8	Transformer Assembly	4-13
4-9	Transformer Assembly Removal	4-14
4-10	Power Distribution Board	4-16
5-1	BA11-K Packaging	5-2
5-2	Connector Specifications	5-3
5-3	Power Control	5-3

TABLES

Table No.	Title	Page
1-1	BA11-K Physical and Environmental Characteristics	1-3
1-2	H765 Power System Physical Characteristics	1-3
1-3	BA11-KE Input Power Electrical Specifications	1-4
1-4	BA11-KF Input Power Electrical Specifications	1-5
1-5	BA11-K Output Power Characteristics	1-6
1-6	Power Up and Power Down Characteristics	1-7
2-1	Unibus Pin Assignments (By Pin Numbers)	2-4
2-2	SU Installation Requirements	2-4
2-3	System Unit Combinations	2-6
2-4	PDP-11 Family Models and Options	2-7
2-5	PDP-11 Family Options	2-8
2-6	Option Harnesses	2-10
2-7	Power Distribution Wire Coding	2-10
4-1	Field Service Maintenance Equipment Required	4-1
4-2	Regulator Specifications	4-4
4-3	H744, H745, H754 Voltage Regulator Troubleshooting Chart	4-5

INTRODUCTION

This manual describes the general specifications, installation, theory of operation, and maintenance procedures that apply to the BA11-K mounting box. The basic BA11-K includes a 10-1/2 inch mounting chassis and power system that is similar to the 11/05-S and 11/35-S chassis and power system. This manual is also used for maintaining and troubleshooting the PDP-11/05-S and PDP-11/35-S power system. The manual is organized as follows:

Chapter 1 describes the characteristics and specifications of the BA11-K.

Chapter 2 describes the system unit configurations, options, and option guidelines applicable to the BA11-K.

Chapter 3 contains a mechanical description of the BA11-K and its contents, and describes the theory of operation.

Chapter 4 describes the BA11-K power system maintenance procedures, and the replacement procedures for failed items.

Chapter 5 details unpacking and BA11-K installation.

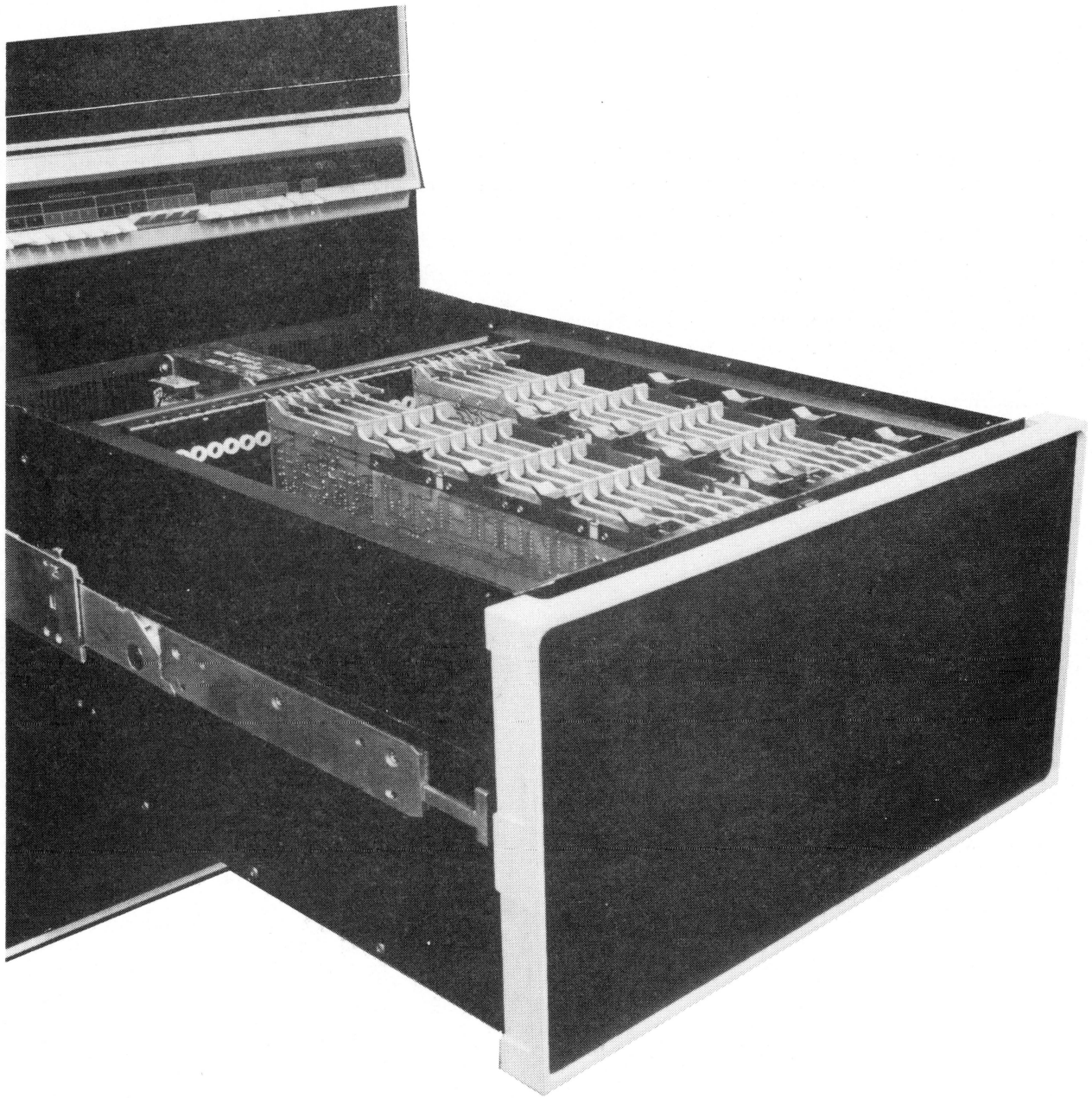

7111-24

Figure 1-1 BA11-K Mounting Box (Top Covers Removed)

CHAPTER 1

BA11-K CHARACTERISTICS AND SPECIFICATIONS

1.1 GENERAL

The BA11-K is a 10-1/2 inch expander box which is mounted in a standard 19-inch rack. It is designed to house the Digital standard system units that make up a PDP-11 expansion system. The expansion system (expander box) can contain memory, peripheral controllers, devices, or options compatible with the PDP-11 family. The BA11-K is modular in design enabling a high degree of serviceability with minimum downtime.

The BA11-K can accept a maximum of five system units providing a great degree of flexibility in selecting a system unit configuration (e.g., single and double system units may be mixed).

There are two basic versions of the mounting box: the BA11-KE for 115 Vac, and the BA11-KF for 230 Vac. These two variations are the result of two ac input boxes, one for each line voltage. The two ac input boxes can be interchanged within the same BA11-K mounting box with no other modifications.

1.2 PHYSICAL CHARACTERISTICS

1.2.1 BA11-K Characteristics

Figure 1-1 shows the BA11-K mounted in a rack. Basically it is composed of a main chassis and an H765 power system. The BA11-KE and BA11-KF are physically identical except for the ac input box in the H765. The BA11-KE (115 Vac) contains a 7009811-1 ac input box; the BA11-KF (230 Vac) contains a 7009811-2 ac input box.

Figure 1-2 is the top view of the physical layout of the BA11-K. The mechanical and environmental specifications are described in Table 1-1.

1.2.2 H765 Power System

The H765 power system is self-contained in its own chassis. It is secured to the main BA11-K chassis with six screws. Two are special-purpose screws which function as hinges,

enabling the H765 to be swung away from the main chassis during maintenance. The H765 power system contains five regulators, two fans, an ac input box, a transformer assembly, and a power distribution board. Four of the regulators are self-contained DEC standard modular types. The fifth regulator is a regulator board that is mounted in the ac input box. Paragraph 4.4 describes the removal procedures for the H765 power system. Table 1-2 lists the H765 Power System's physical characteristics.

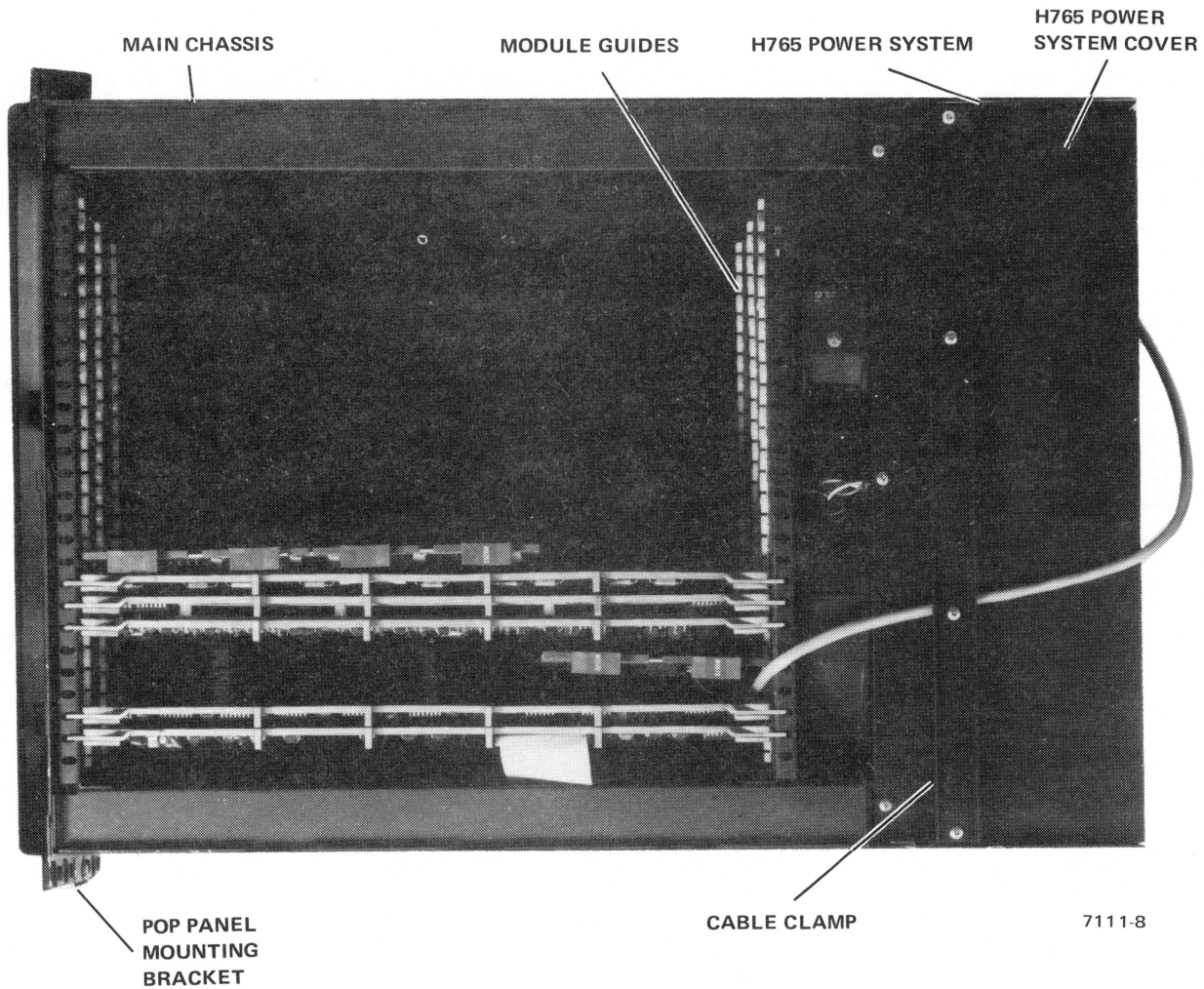

Top View - Main Chassis Cover Removed

Figure 1-2 BA11-K Physical Layout

Table 1-1
BA11-K Physical and Environmental Characteristics

Item	Description
Chassis size (with H765 power system and pop panel)	10.44 in. high, 17.12 in. wide, 26.53 in. deep
Chassis size (with H765 power system without console panel and bezel)	10.44 in. high, 17.12 in. wide, 25 in. deep
Chassis size (without H765 power system, console panel and bezel)	10.44 in. high, 17.12 in. wide, 17.25 in. deep
BA11-K expander box chassis weight (without system units)	87 lb
H765 power system size	10.38 in. high, 17.12 in. wide, 7.75 in. deep
Slide extension (three-section slide)	27 in. maximum
Slide weight capacity (BA11-K fully extended)	150 lb
Three-stop slide	Positions: Horizontal, 45 degrees, and 90 degrees (front panel facing up)
Fan air movement direction	Horizontally toward rear of BA11-K
Module slots	22 maximum (2 double system units and 1 single system unit) using DEC standard configuration backplanes
Operating temperature range at inlet to box	41° F–122° F (5° C–50° C)
Operating humidity	10 to 95% (no condensation)
Cooling efficiency for both fans at 90 Vac, 50 Hz	Temperature rise no greater than 18° F (10° C) from inlet air temperature to exhaust air

Table 1-2
H765 Power System Physical Characteristics

Item	Description
H765 power system contents	H744 regulators (two) (+5 V) H745 regulator (-15 V) H754 regulator (+20 V, -5 V) 5411086 regulator (+15 V)* 7010014 transformer assembly 7009811-1 or -2 ac input box with 5410993 power control board 5410864 power distribution board 1211714 box fans (two)
Fan size	6 in.
Fan type	Ball bearing
Fan capacity at 115 V, 50 Hz	260 cfm at 0 static pressure
Fan efficiency at 90 Vac, 50 Hz	60%
7010014 transformer assembly weight	25 lb

*Early versions of the BA11-K may contain a 5409730-YA regulator in place of the 5411086 regulator.

1.3 ELECTRICAL SPECIFICATIONS

1.3.1 BA11-KE, BA11-KF Input Power Electrical Specifications

The BA11-KE and KF are electrically identical except for the ac input box. A BA11-KE expander box designation

indicates that the input voltage is 115 Vac and that a 7009811-1 ac input box is installed in the H765 power system. A BA11-KF expander box designation indicates that the input voltage is 230 Vac and that a 7009811-2 ac input box is installed in the H765 power system. Tables 1-3 and 1-4 contain the input power electrical specifications of the BA11-KE and KF, respectively.

**Table 1-3
BA11-KE Input Power Electrical Specifications**

Parameter	Specification
Input power	90–132 Vac, 115 Vac nominal, 47–63 Hz, single phase
Inrush current	175 A peak for 10 ms max. at 115 V line voltage
Input power	1200 W maximum at 115 V nominal line voltage
Input current	12 A max at 115 Vac
Circuit breaker rating	20 A at 115 Vac
Power factor	The ratio of input power to apparent power must be greater than 0.85
Conducted Noise (noise on ac line) Transients	<p>Single transient without loss of data: 300 V at 0.2 W sec max.</p> <p>Single transient, survival: 1000 V at 2.5 W sec max.</p> <p>Average transient power survival: 0.5 W max.</p>
CW Noise	<p>10 KHz – 3 MHz: 3 V rms</p> <p>3 MHz – 500 MHz: 1 V rms</p> <p>500 MHz – 1000 MHz: 0.5 V rms</p>
RF field susceptibility	10 KHz – 1000 MHz: 1 V/M
Power fail	<p>H765 power system is capable of withstanding power interruptions of any magnitude and duration without damage. Storage time of power supply at low line and full load shall be 20 ms minimum. Storage time is measured from the time the power outage occurs until the time the regulator voltages listed in Table 1-5 drop below their specified regulation limits.</p>

**Table 1-4
BA11-KF Input Power Electrical Specifications**

Parameter	Specification
Input power	180 – 264 Vac, 230 Vac nominal, 47–63 Hz, single phase
Inrush current	80 A peak for 10 ms max. at 230 Vac line voltage
Input power	1200 W maximum at 230 Vac nominal line voltage
Input current	6 A max at 230 Vac
Circuit breaker rating	10 A at 230 Vac
Power factor	The ratio of input power to apparent power shall be greater than 0.85
Conducted Noise (noise on ac line) Transients	<p>Single transient, without loss of data: 300 V at 0.2 W sec</p> <p>Single transient, survival: 1000 V at 2.5 W sec max.</p> <p>Average transient power survival: 0.5 W maximum</p>
CW Noise	<p>10 KHz – 3 MHz: 3 V rms</p> <p>3 MHz – 50 MHz: 1 V rms</p> <p>500 MHz – 1000 MHz: 0.5 V rms</p>
RF field susceptibility	10 KHz – 1000 MHz: 1 V/M
Power fail	<p>H765 power system is capable of withstanding power interruptions of any magnitude and duration without damage. Storage time of power supply at low line and full load shall be 20 ms minimum. Storage time is measured from the time the regulator voltages listed in Table 1-5 drop below their specified regulation limits.</p>

1.3.2 BA11-K Output Power Specifications

The BA11-K output power is determined by the rating of the regulators (Figure 1-3) listed in Table 1-5. Due to the

great degree of flexibility and options available, each BA11-K configuration must be analyzed for total load requirements. Once the current drain of the options is

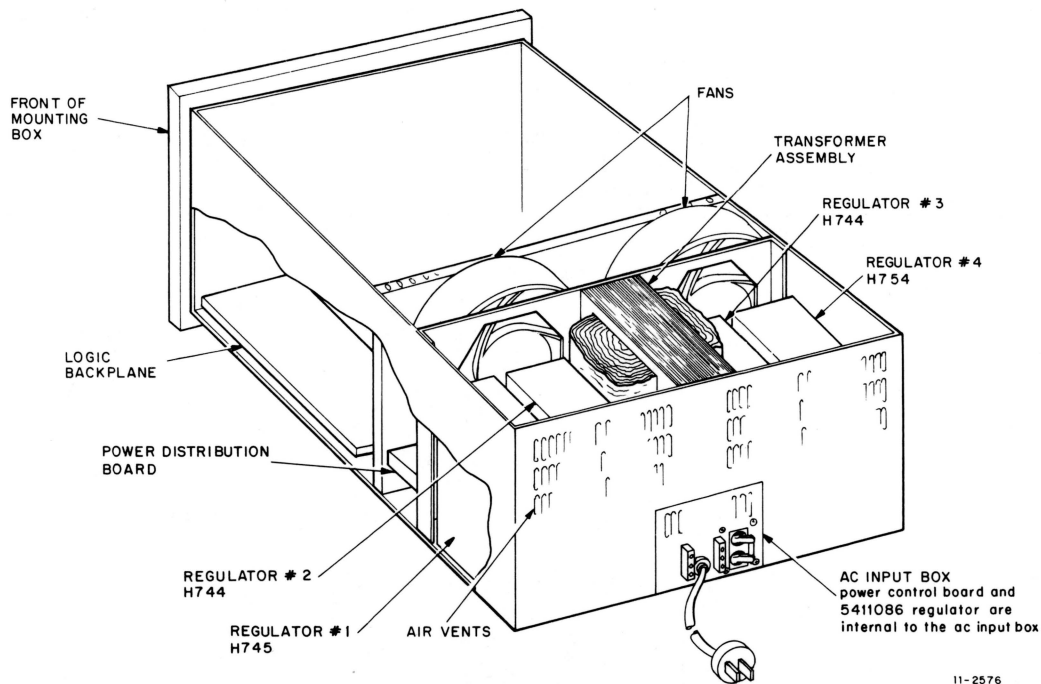

Figure 1-3 Physical Layout of H765 Power Supply

Table 1-5
BA11-K Output Power Characteristics

Regulator	Voltage and Regulation	Output Current (max)	Power Distribution Board Jacks	Peak-to-Peak Ripple (max)
H745 (No. 1)	-15 Vdc \pm 750 mV	10 A	J3, J5, J7, J9, J11	450 mV
H744 (No. 2)	+5 Vdc \pm 250 mV	25 A	J9, J11	200 mV
H744 (No. 3)	+5 Vdc \pm 250 mV	25 A	J3, J5, J7	200 mV
H754 (No. 4)	+20 Vdc \pm 1 V -5 Vdc \pm 250 mV	8 A 1 A - 8 A [†]	J3, J5, J7, J9, J11	5%* 5%*
5411086**	+15 Vdc \pm 1.5 V	4 A	J3, J5, J7, J9, J11	3%
	AC LO, DC LO LTCL	-	J4, J6, J8, J10, J12	-

*At backplane. Typical ripple \pm 3%.

**Early versions of the BA11-K may contain a 5409730-YA regulator in place of the 5411086 regulator.

[†]Maximum -5 V current is dependent upon +20 V current. It is equal to 1 A plus the current of the +20 V supply, up to a total of 8 A.

totalled, it should be compared with the output currents listed in Table 1-5. (See Tables 2-4 and 2-5 for a list of some of the available options and their load requirements.) When configuring the expansion system, care must be taken to ensure that the options do not exceed the current capabilities of the regulators.

1.3.3 Power Up, Power Down Characteristics

The BA11-K power up and power down characteristics are determined by regulator 5411086. A complete description of this regulator, along with a timing diagram, is in Chapter 3. Table 1-6 lists the dynamic and static power up and power down characteristics of regulator 5411086.

**Table 1-6
Power Up and Power Down Characteristics**

Parameter	Specification
Dynamic Performance (Figure 3-8)	
BA11-K Power Down	4 ms min from ac Power Down to AC LO L asserted
	5 ms min from AC LO L asserted to DC LO L asserted
BA11-K Power Up	1 ms min from +15 V to DC LO L negated
	2 ms nominal from DC LO L negated to AC LO L negated
Static Performance at full load*	
BA11-K Power Down	AC LO L drops to LOW: 83–88 Vac
	DC LO L drops to LOW: 73–78 Vac
BA11-K Power Up	DC LO L goes to HIGH: 75–80 Vac
	AC LO L goes to HIGH: 85–90 Vac

*Response to changing ac input (less than 10/V second).

CHAPTER 2

SYSTEM UNITS, OPTIONS, HARNESSSES, AND INSTALLATION INFORMATION

2.1 GENERAL

This chapter details the configuration and expansion capabilities of the BA11-K mounting box. The configuration and expansion information should not only be used for initial installation, but also used as an ongoing aid when adding or modifying system units. The following paragraphs describe the items listed below:

- DEC system units
- BA11-K system unit configurations
- System unit installation
- Option configurations
- Harness information
- Cable routing
- Cabinet mounting specifications

2.1.1 Introduction to System Units

The system unit is the basic mounting assembly for PDP-11 logic. Logic module and cable connectors plug into the module side of the system unit. The other side of the system unit contains either backplane wiring or etched board wiring which connects the pins together. A system unit connects to another system via the Unibus. Four slots of a system unit are reserved for Unibus connections. These are slots A and B of the first and last slots as shown in Figure 2-1.

The following types of system units are utilized in the PDP-11 system.

Dedicated – Dedicated system units are prewired and tested for specific functions such as processor, memory, or disk controller.

General Purpose – General purpose system units use a standard backplane wiring which has been established for the controllers of small peripherals, such as printers, card readers, and terminals. Each system unit has four small peripheral controller (SPC) slots with wiring provided for signal conditioning options. A variety of general purpose interfaces, communications devices, and options are available for use in these SPC slots.

Blank – Unwired single system units are made available for OEM use, enabling custom application.

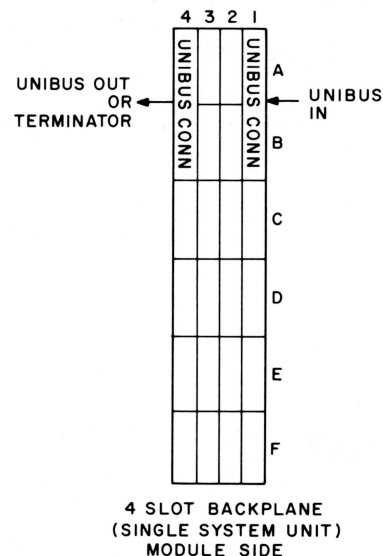

11-2758

Figure 2-1 Standard Unibus Connection

The BB11 blank mounting panel (Figure 2-2) is a prewired system unit (SU) designed for general interfacing. It is prewired only for the Unibus and power. The unit contains three 288-pin blocks assembled end-to-end in a casting which can be mounted in the various PDP-11 assembly units. Bus and power connectors, described below, use only 6 of the module slots, leaving 18 slots available for customer use.

The BB11 is wired to accept the Unibus in slots A1 and B1. This connection can be made with an M920 Unibus connector or a BC11A Unibus cable assembly. All bus signals, including grant signals, are wired directly to

corresponding pins in slots A4 and B4. From this point, the Unibus can be continued to the next unit by using an M920 or BC11A. If the BB11 is the last unit on the bus, slot A4-B4 accepts the M930 bus terminator module.

The bus grant signals are wired through the BB11. These grant signal wires must be removed and replaced with wires to and from the user's control circuits for the grant levels used by the customer-supplied device.

Power for +5 V is distributed to all A2 pins; -15 V is distributed to all B2 pins except in slots A1, B1, A4, and B4; and ground is maintained through the frame and power connector on pins C2 and T1 of all slots.

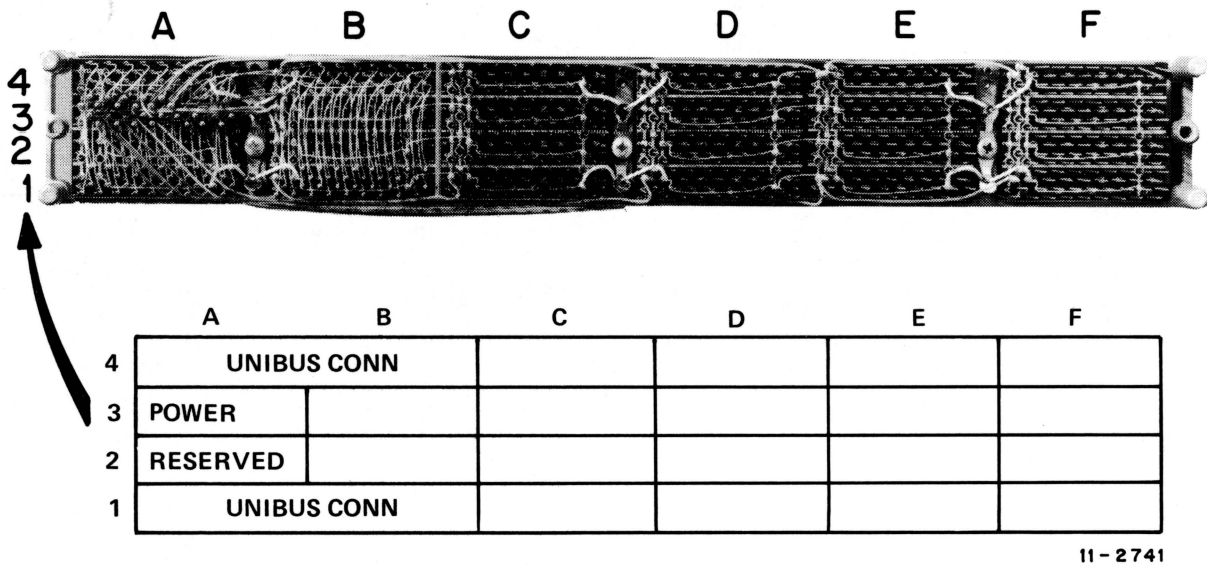
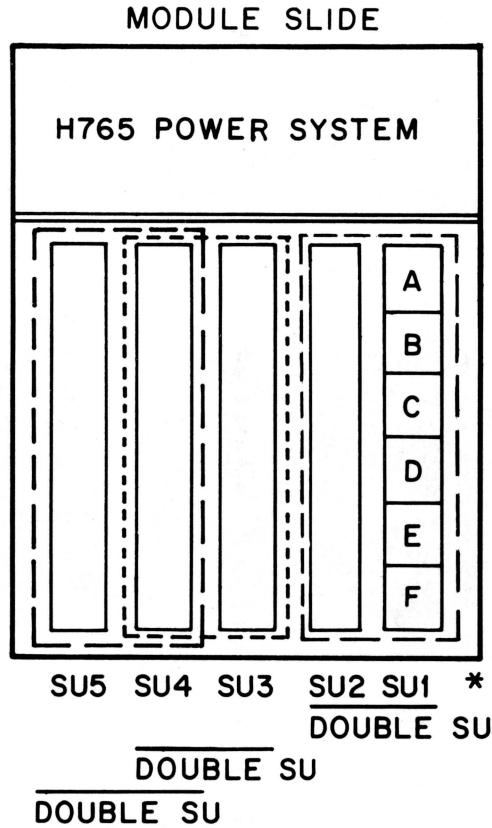

Figure 2-2 BB11 Single System Unit

2.1.2 BA11-K System Unit Configuration

Using DEC standard logic planes, the BA11-K has the following configuration capabilities (Figure 2-3).

1. Five single-system units, 20 slots. (A system unit is a four-slot logic backplane.)
2. One double-system unit and three single-system units. (A double system unit is a nine-slot logic backplane.)
3. Two double-system units and one single-system unit.



* If a single system unit is installed in location SU1 a double system unit cannot be installed in locations SU2 and SU3 due to power distribution board layout.

II-2564

Figure 2-3 System Unit Configurations

2.1.3 Unibus Pin Assignments

Table 2-1 lists the Unibus pin assignments for slots A and B of a system unit. These pin assignments are applicable regardless of the type PDP-11 system unit selected.

Table 2-1
Unibus Pin Assignments
(By Pin Numbers)

Pin	Signal	Pin	Signal
AA1	INIT L	BA1	BG 6 H
AA2	POWER (+5 V)	BA2	POWER (+5 V)
AB1	INTR L	BB1	BG 5 H
AB2	GROUND	BB2	GROUND
AC1	D00 L	BC1	BR 5 L
AC2	GROUND	BC2	GROUND
AD1	D02 L	BD1	GROUND
AD2	D01 L	BD2	BR 4 L
AE1	D04 L	BE1	GROUND
AE2	D03 L	BE2	BG 4 H
AF1	D06 L	BF1	ACLO L
AF2	D05 L	BF2	DCLO L
AH1	D08 L	BH1	A01 L
AH2	D07 L	BH2	A00 L
AJ1	D10 L	BJ1	A03 L
AJ2	D09 L	BJ2	A02 L
AK1	D12 L	BK1	A05 L
AK2	D11 L	BK2	A04 L
AL1	D14 L	BL1	A07 L
AL2	D13 L	BL2	A06 L
AM1	PA L	BM1	A09 L
AM2	D15 L	BM2	A08 L
AN1	GROUND	BN1	A11 L
AN2	PB L	BN2	A10 L
AP1	GROUND	BP1	A13 L
AP2	BBSY L	BP2	A12 L
AR1	GROUND	BR1	A15 L
AR2	SACK L	BR2	A14 L
AS1	GROUND	BS1	A17 L
AS2	NPR L	BS2	A16 L
AT1	GROUND	BT1	GROUND
AT2	BR 7 L	BT2	C1 L
AU1	NPG H	BU1	SSYN L
AU2	BR 6 L	BU2	C0 L
AV1	BG 7 H	BV1	MSYN L
AV2	GROUND	BV2	GROUND

2.1.4 System Unit Installation

The installation of a system unit (SU) requires the items listed in Table 2-2.

The following steps outline the procedure to be used when installing a system unit.

1. Install the required number of system units in the BA11-K and secure them to the mounting boxes using the screws provided. The system units are installed with slot A adjacent to the power distribution board. Figure 2-4 shows a double system unit installed in a BA11-K box configuration.

NOTE

Figure 3-12 illustrates the correct connections for the H744 regulator.

2. Install a Unibus jumper module (M920) from the last slots A and B (see Figure 2-1) of the first SU to adjacent SU slots A and B. This extends the system Unibus continuity to each logic backplane in the BA11-K.
3. The Unibus In should be connected to the first slot (A1 and B1) of the first SU. The Unibus Out should be connected to the last slot of the last SU in the BA11-K.
4. Ensure that the M930 terminator module is plugged into the last SU slot (slots A and B) when terminating the Unibus.

Table 2-2
SU Installation Requirements

Quantity	Item	Remarks
1	Backplane	
1	Power harness	See Tables 2-4 and 2-5.
1	M920 Unibus jumper module	Unless the SU is the first installed in a BA11-K expansion box.

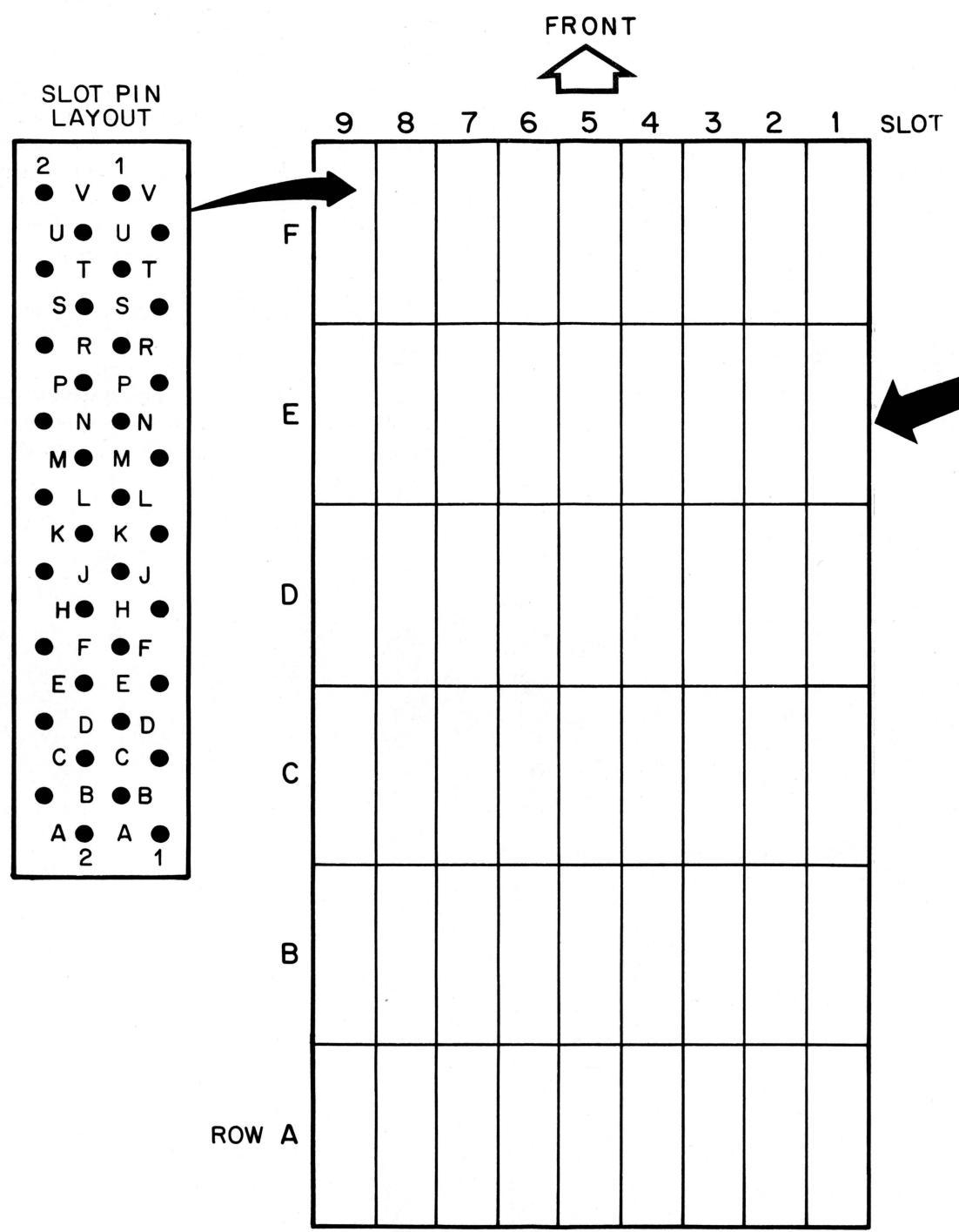

VIEW FROM WIRE WRAP PIN SIDE.
COMPUTER IN MAINTENANCE POSITION

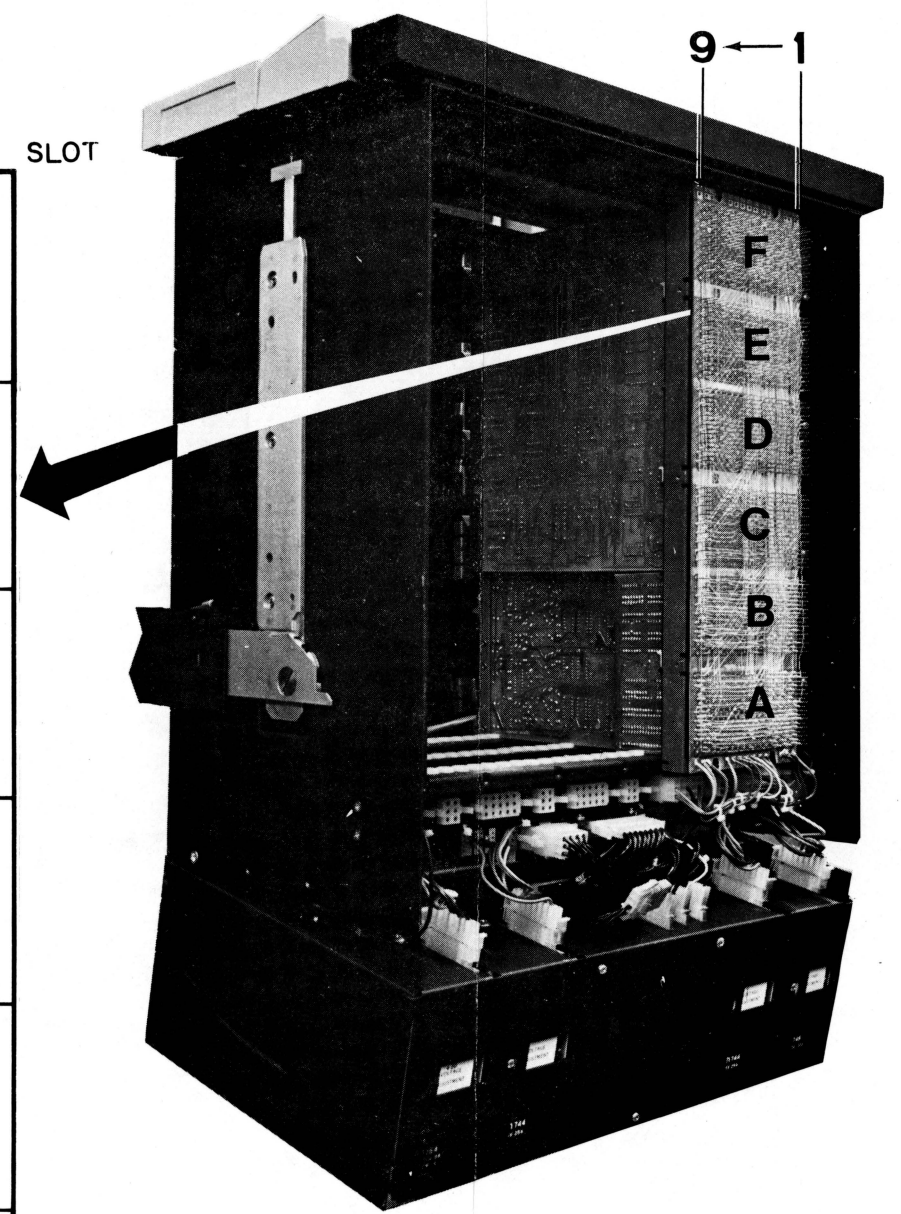

11-2735

Figure 2-4 BA11-K with Double System Unit (Wire Wrap Side)

Table 2-3 lists the various combinations of system units that can be installed in the BA11-K.

**Table 2-3
System Unit Combinations**

Variations	System Unit Combinations*
1	2 double system units and 1 single system unit
2	3 single system units and 1 double system unit
3	5 single system units

*Double system units are prewired DEC configurations.

2.2 OPTION CONFIGURATIONS

Utilizing two double system units, and one single system unit, or a variation of these, the BA11-K can accept as many as 16 hex and 6 quad module circuit boards. Due to the power that these system units could require, care must be taken to assure that the power capabilities of the BA11-K H765 power system, is not exceeded. To aid in a safe, reliable module configuration Tables 2-4 and 2-5 have been included in this section. These tables list the various DEC module or system unit options with its dc and ac power requirements. Also included in Tables 2-4 and 2-5 are the power harness options, if applicable.

NOTE

Power harnesses used in other mounting boxes may not be applicable to the BA11-K.

Table 2-4
PDP-11 Family Models and Options

Model/Option	Description	+5 V (CPU)	Current Needed (Amperes)					AC Line Current (Amperes)
			+5 V (Options)	-15 V	+20 V	-5 V	+15 V	
H765 A/B	BA11-K Power Supply	25	25	10	8	8	4	2.5
	H744							2.5
	H745							2.5
	H754							3.3
	5411086							
11/05-S	KD11-B	8.0		0.25			0.05	
	MM11-U	5.4			4.4	0.51		
	3 SPC	6.0						
	2 M930's	2.5						
	Total Amperes	16.6		0.25	4.4	0.51	0.05	5.0
11/35-S	KD11-A	10.5						
	KE11-F	2.0						
	KE11-E	3.0						
	KJ11-A Optional	0.5						
	KT11-D	2.5						
	KW11-L	0.5						
	SPC	2.0						
	M981		1.25					
	MF11-U (16K)		6.1					
	M930		1.25					
	Total Amperes	21	8.6		4.4	0.51		6.0
MF11-U/MM11-U* (Active)	16K Sense							
	Core Memory		6.1		4.4	0.51		2.2
(Standby)	(Double SU)		5.4		0.56	0.41		0.8
MF11-UP/MM11-UP (Active)	16K Sense							
	Core with Parity		7.3		4.4	0.51		2.3
(Standby)	(Double SU)		5.4		0.56	0.41		0.8
MF11-L (MM11-L) (Active)	8K Core							
	Memory		3.4	6.0				1.8
(Standby)	(Double SU)		1.7	0.5				0.3
MF11-LP (MM11-LP) (Active)	8K Parity							
	Core Memory		4.9	6.0				2
(Standby)	(Double SU)		1.7	0.5				0.3
MM11-S	Same as MM11-L Except in SU Configuration (1 SU)		Same as MF11-L					

*Non-Interleaved.

Table 2-5
PDP-11 Family Options

Option	Mounting Code	Description	Power Harness	Current Needed (Amperes)					AC Line Current (Amperes)
				+5 V	-15 V	+20 V	-5 V	+15 V	
AA11-D	1 SU	Digital to Analog Converter Subsystem	7009562	3.0					0.3
AR-11	SPC	ADC and DAC's	N/A	5.0					0.5
BA614	(AA11-D)	D/A Converter		3.0					0.3
BM792-Y	SPC	Bootstrap Loader		0.3					0.3
CD11-A/B	1 SU	1000 CPM, 80 Col. Card Reader Controller	7010117	2.5					0.25
CD11-E	1 SU	1200 CPM, 80 Col. Card Reader Controller	7010117	2.5					0.25
CM11	SPC	200 CPM, 80 Col. Card Reader Controller		1.5					0.15
CR11	SPC	300 CPM, 80 Col. Card Reader Controller		1.5					0.15
DA11-DB	1 SU	Unibus Link		4.0					0.4
DA11-F	1 SU	Unibus Window	7010117	5.0					0.5
DB11-A*	1 SU	Bus Repeater	7009562	3.2					0.31
DC11-A	1 SU	Dual Clock and System Unit	7010117	0.2					0.02
DC11-DA	(DC11-A)	Full Duplex Module Set		2.0	0.2			0.2	0.2
DD11-B	1 SU	Peripheral Mounting Panel	7010117						
DH11-AA	DLB SU	Prog Async 16-Line Multiplexer	7010118	8.4	0.42				0.9
DH11-AD	DLB SU	@ Modem Control	7010118	10.8	0.665			0.4	1.33
DJ11-A	1 SU	Async 16-Line MUX	7010117	4.7	0.25			0.25	0.6
DJ11-AC	1 SU	Async 16-Line MUX			1.0				0.25
DL11	SPC	Async Interface		1.8	.15			.016	0.21
DM11-B	(DH11)	16-Line Modem Control	(DH11)	2.4					0.24
DN11-A	1 SU	Auto Calling System Unit	7009562	2.6					2.5
DP11-D	1 SU	Half/Full Duplex Sync Interface	7009562	2.56	0.07			0.04	0.28
DP11-C	(DP11-D)	Data/Sync Register Extender		0.77					0.08
DP11-K	(DP11-D)	Internal DP11 Clock		0.18					0.02
DQ11-D	1 SU	Full/Half Duplex Sync Interface	7010117	6.0	0.07			0.04	0.62
DQ11-E	1 SU	Full/Half Duplex Sync Interface	7010117	6.0	0.07			0.04	0.62

*When installing a DB11-A bus repeater in a BA11-K 10-1/2 in. mounting box, the AC LO and DC LO wires must be removed from the harnesses of all the options (located in the same box) after the DB11-A.

Table 2-5 (Cont)
PDP-11 Family Options

Option	Mounting Code	Description	Power Harness	Current Needed (Amperes)					AC Line Current (Amperes)
				+5 V	-15 V	+20 V	-5 V	+15 V	
DFC11-A	(DU/DP CLOCK)	Level Converter Clock Recovery		0.4	0.02			0.02	0.05
DQ11-K	(DQ11-D/A)	Crystal Clock			0.05				0.012
DR11-B	SPC	General Purpose DMA	7009562	3.3					0.32
DR11-C	1 SU	General Purpose Digital Interface		1.5					0.15
DR11-K	SPC	Digital I/O		N/A	0.15				0.6
DU11-D	SPC	Full/Half Duplex		2.2	2.5			0.05	0.27
DU11-EA	SPC	Sync Prog. Interface		2.6	0.20			0.07	0.33
DV11	DBL SU	Sync MUX	13.5	.083				0.435	0.5
KG11-A	SPC	Comm Arith Unit		1.2					0.12
KW11-L	(CPU)	Line Clock		0.8					0.08
KW11-P	SPC	Prog Line Clk		1.0					0.1
LC11-A	SPC	LA30 Control		1.5					0.15
LP11-R	SPC	1200 LPM Printer		1.0					0.1
LP11-S	SPC	900 LPM Printer		1.0					0.1
LP11-W	SPC	240 LPM Printer		1.5					0.15
LP11-V	SPC	300 LPM Printer		1.5					0.15
LS11-A	SPC	60 LPM Printer		1.5					0.15
LV11-B	SPC	Electrostatic Printer, 500 LPM		1.5					0.15
MR11-DB	2 SPC	Bootstrap							
PC11	SPC	Paper Tape		1.5					0.15
PR11	SPC	Paper Tape (Reader)							
RH11	DBL SU			1.9					0.19
RK11-D	SU	Disk and Cntrl	7010115	8.0					0.8
TA11-A	SPC	Dual Cassette Interface							
VT11	SU	Graphic Processor		6.5	100				0.8
VR11-A	SPC	Push Button Box		4					0.4

2.3 COMPUTER OPTION AND MAIN POWER WIRE HARNESSSES

Table 2-6 is a list of typical PDP-11 family wire harnesses.

2.4 POWER DISTRIBUTION WIRE COLOR CODING

Table 2-7 lists the standard colors used for dc power and signal distribution to the backplanes.

**Table 2-7
Power Distribution Wire Coding**

DC Power/Signal	Color of Wire
Ground	Black
Line clock (LTCL)	Brown
DC LO	Violet
AC LO	Yellow
+5 V	Red
-5 V	Brown
+15 V	Gray
-15 V	Blue
+20 V	Orange

**Table 2-6
Option Harnesses**

CPU Type Option	11/35-S, 11/05-S BA11-KE/F 10-1/2 in. Box	11/05, 11/10 BA11-D 10-1/2 in. Box	11/35 BA11-D 10-1/2 in. Box	11/45 (Old)	11/40 H960D/E, BA11-F (Old) ****	11/40, 11/45 H960D/E, BA11-F (New)
AA11-DA	70-9562	70-9205	70-9205	70-8855	70-8909	70-9562
AA11-DB	70-9562	70-9205	70-9205	70-8855	70-8909	70-9562
DA11-F	70-10117	70-9099	70-9099	70-9162	70-9099	70-9563
DB11-A	70-9562	70-9205	70-9205	70-8855	70-8909	70-9562
DC11-A	70-9562	70-9205	70-9205	70-8855	70-8909	70-9562
DD11-A	70-9562	70-9205	70-9205	70-8855	70-9177	70-9562
					70-8909	
DD11-B	70-10117	70-9099	70-9099	70-9162	70-9099	70-9563
DH11-AA	70-10118	N/A	N/A	N/A	70-9466	70-9561
DH11-AB	70-10118	N/A	N/A	N/A	70-9466	70-9561
DH11-AC	70-10118	N/A	N/A	N/A	70-9466	70-9561
DJ11-AA	70-10117	70-9099	70-9099	70-9162	70-9099	70-9563
DJ11-AB	70-10117	70-9099	70-9099	70-9162	70-9099	70-9563
DJ11-AC	70-10117	70-9099	70-9099	70-9162	70-9099	70-9563
DN11-AA	70-9562	70-9205	70-9205	70-8855	70-8909	70-9562
DP11-DA	70-9562	70-9205	70-9205	70-8855	70-8909	70-9562
DR11-B	70-9562	70-9205	70-9205	70-8855	70-8909	70-9562
MF11-L*	N/A	70-9206	70-9206	70-9242	70-9103	70-9565
MF11-L**	70-10114	N/A	N/A	N/A	70-9174	70-9560
MF11-LP*	N/A	N/A	70-9206	70-9242	70-9103	70-9565
MF11-LP**	70-10114	N/A	N/A	N/A	70-9174	70-9560
MF11-U***	70-10115	N/A	N/A	N/A	N/A	70-9535
MF11-UP****	70-10115	N/A	N/A	N/A	N/A	70-9535
MM11-S	70-9562	70-9205	70-9205	70-8855	70-8909	70-9562
RH11	70-9570	70-9099	70-9099	70-9162	70-9571	70-9570
RH11-AB	70-10117	70-9099	70-9099	70-7162	70-9099	70-9563
RK11-D	70-10116	70-8992	70-8992	70-8855	70-8992	70-9559
VT11	70-10117	70-9099	70-9099	70-9162	70-9099	70-9563
CD11 A/B,E	70-10117	70-9099	70-9099	70-9162	70-9099	70-9563
DQ11	70-10117	70-9099	70-9099	70-9162	70-9099	70-9563

* 11/40 only (1st MF11-L/LP)

** 11/40 only (2nd MF11-L/LP)

*** MF11-U/UP cannot be mounted in old style 11/45 CPU box.

****Use 70-9177 if due to new module guide layout, 70-8909 cables are too short.

2.5 UNIBUS AND COMMUNICATION CABLE ROUTING

Figure 2-5 illustrates the routing of Unibus and communication cables in the BA11-K. The routing shown should be used as a guide, taking the following rules into consideration.

1. The maximum height of the cable or cables routed through the BA11-K is 1/2 inches. This is due to the room available under the top cover and cable clamp.

2. Unibus cables should be kept separate from other cables, if possible, to avoid cross talk.
3. Ensure that there is a layer of foam between each Unibus cable when the Unibus cables are stacked.
4. Care should be exercised when routing flat cables to minimize blockage of the exhaust air vents. These air vents are located in back of the BA11-K on each side of the transformer assembly (Figure 1-3).

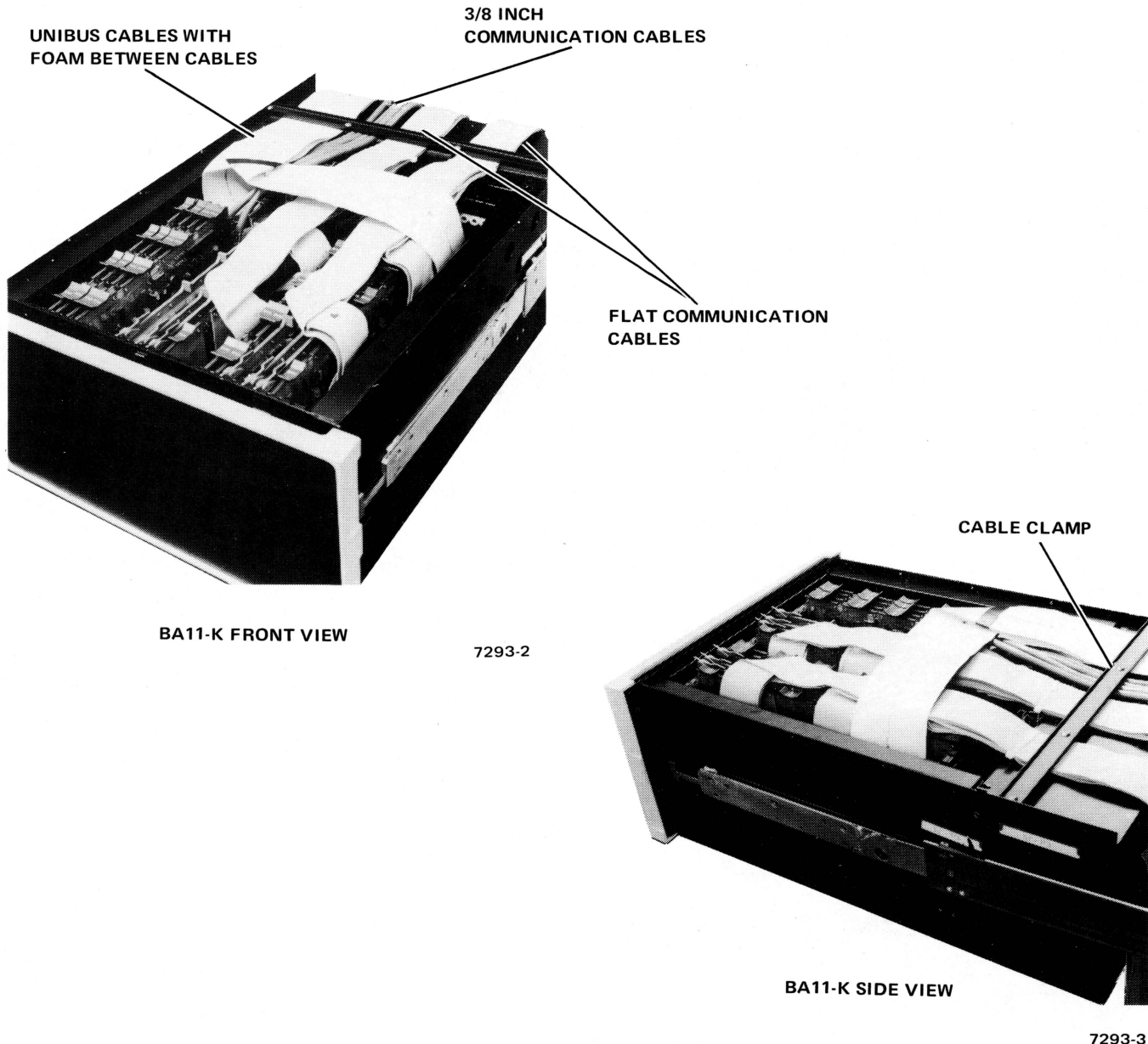
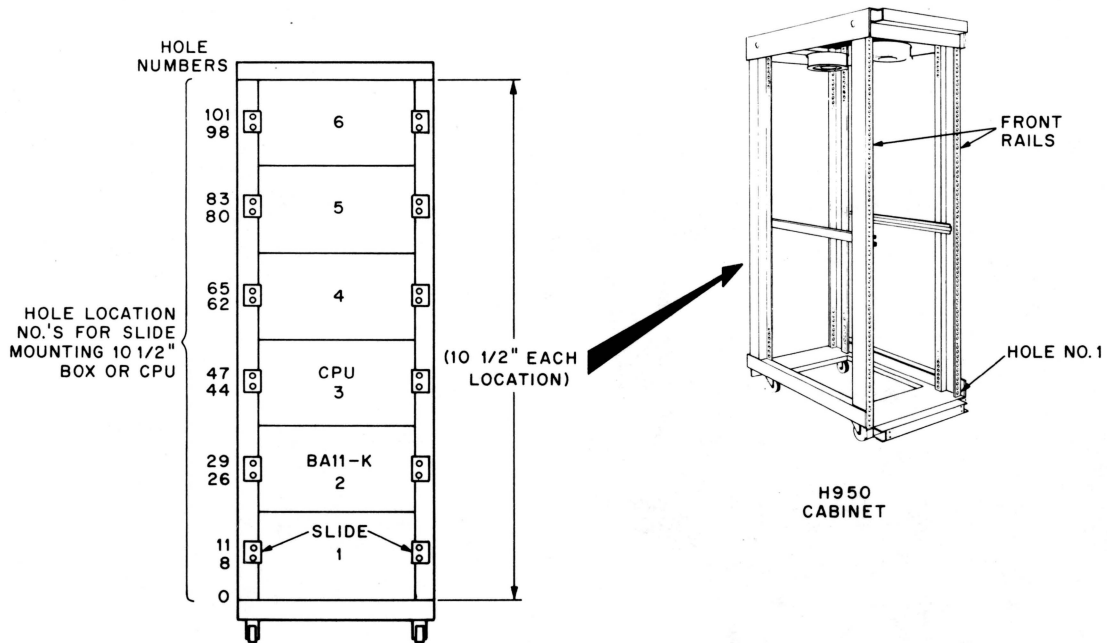

Figure 2-5 Cable Routing

2.6 CABINET AND SLIDE MOUNTING SPECIFICATIONS

The BA11-K and a 10-1/2 inch CPU can be mounted in a H950 cabinet. When using a H950 cabinet the standard configuration is to place the CPU in location 3 and the BA11-K in location 2 (shown in Figure 2-6). The hole numbers shown on Figure 2-6, indicate the exact physical

location for mounting an Accuride or Chassis-Trak slide on the front rail. Although the front rail slide placement is identical for both slides, there are some mounting differences when fastening the slides to a chassis. Figures 2-7 and 2-8 illustrate the specific slide mounting specifications for Accuride and Chassis-Trak, respectively.



11-2740

Figure 2-6 BA11-K and CPU Cabinet Mounting Specification

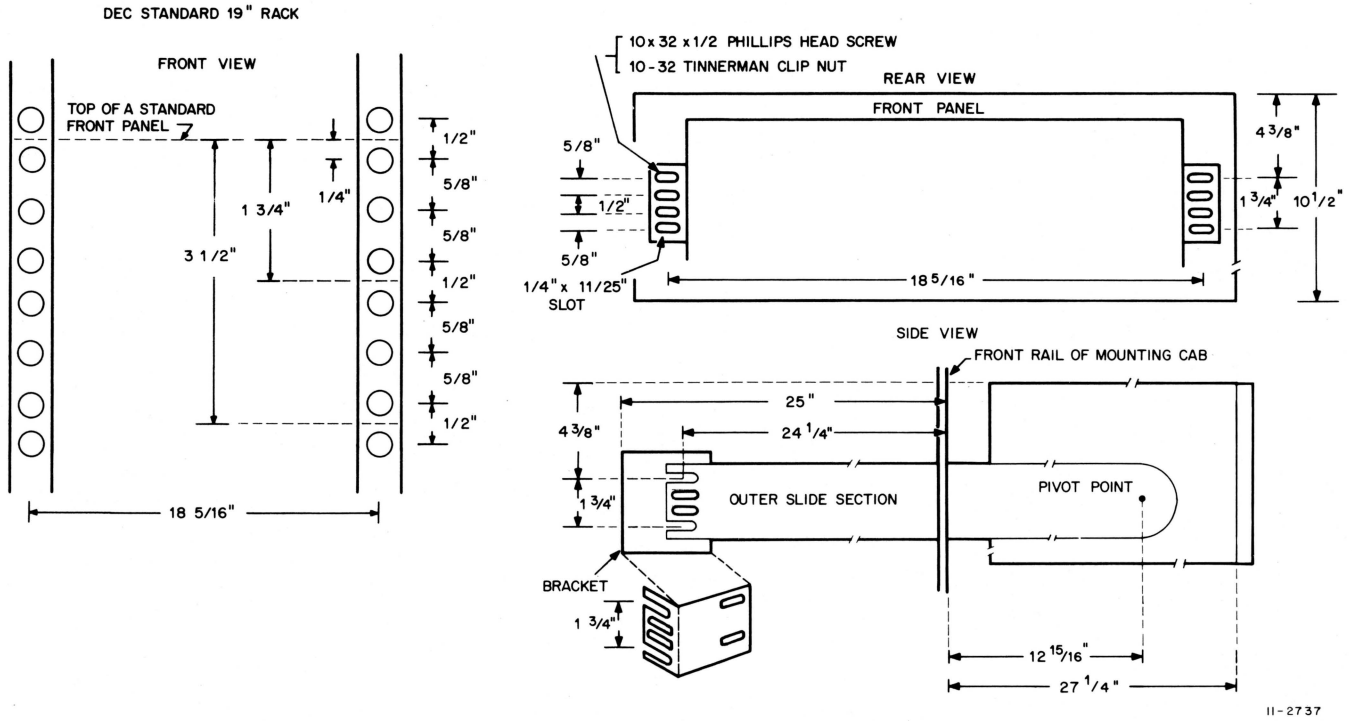

Figure 2-7 Accuride Slide Mounting Specification

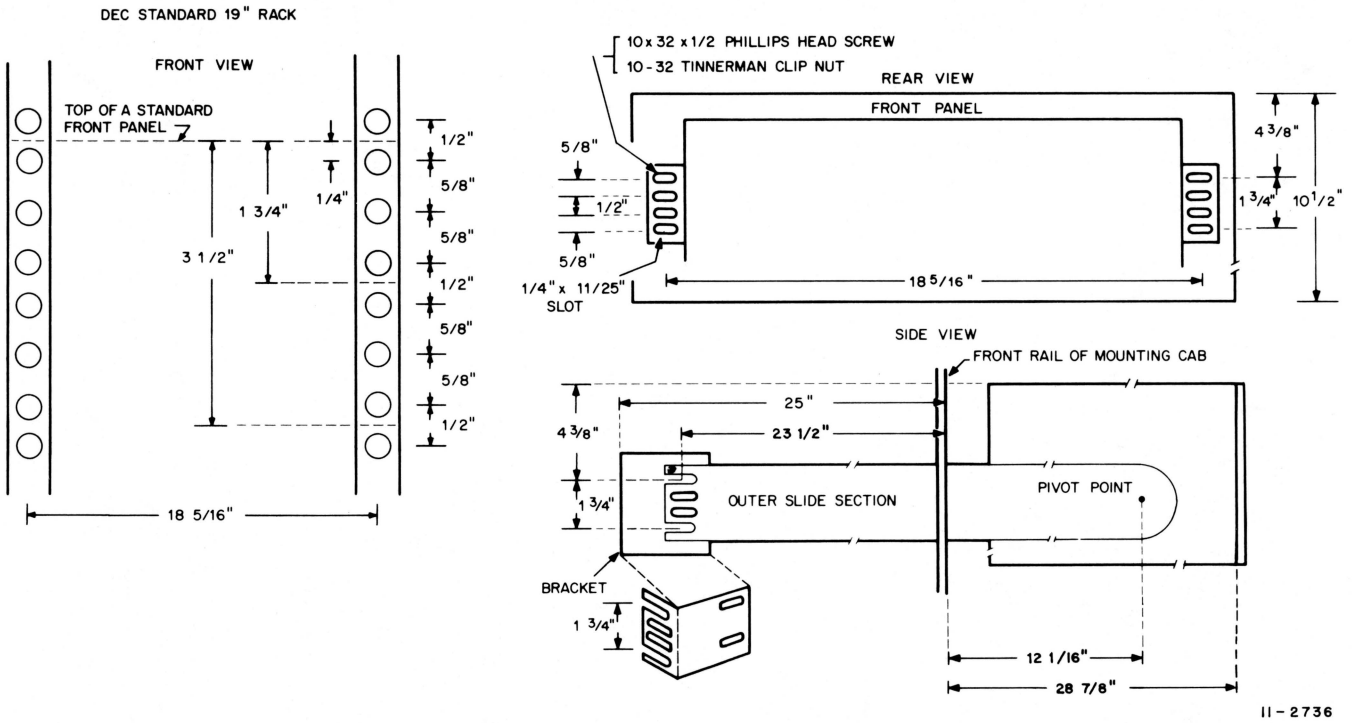

Figure 2-8 Chassis-Trak Slide Mounting Specification

CHAPTER 3

H765 POWER SYSTEM

3.1 INTRODUCTION

This chapter provides mechanical and functional descriptions of the H765 power system. A detailed electrical interconnection diagram is included. The regulator circuits, which are part of the H765 power system, are discussed in detail.

3.2 MECHANICAL DESCRIPTION

The H765 power system consists of two H744 regulators (+5 V), a H745 regulator (-15 V), a H754 regulator (+20 V, -5 V), a 5411086 regulator (+15 V), a 7010014 transformer assembly, a 7009811-1, -2 ac input box, a 5410864 power distribution board, and two 1211714 fans. The contents of the power system are primarily housed in a welded steel chassis.

The chassis is rectangular and measures approximately 7-3/4 in. long by 10-1/2 in. high by 17 in. wide. The H765 power system top cover is held in place by seven screws. The main structural member contains cutouts and drill holes which enable screws to be inserted for securing the regulators, ac distribution box, transformer assembly, and fans. Cutouts for the regulators allow the regulator ON indicators to be monitored and the regulator output voltages to be adjusted.

3.2.1 H744, H745, and H754 Regulators

These regulators are secured to the H765 power system chassis with three Phillips head screws. The mounting screws pass through the H765 chassis holes and screw into the regulator. A plastic (Lexon) shield is installed on the component side of each regulator. This permits visual inspection of the regulator components once the regulator is removed from the H765 chassis. The fuse, which is located on the component side, is accessed by removing the plastic shield. Each regulator contains one potentiometer, except the H754, which contains two potentiometers. An output indicator lamp is located next to the potentiometer. The output of the regulators is terminated in a Mate-N-Lok connector.

3.2.2 5411086 Regulator

The 5411086 regulator is contained on a printed circuit board mounted within the ac input box. It is secured in place when the ac input box is installed in the H765 power system. The inputs and outputs of the regulator are terminated in two Mate-N-Lok connectors.

3.2.3 7010014 Transformer Assembly

This transformer assembly is located in the center of the H765 chassis. Two capacitors, two varistors, and two terminal strips are mounted directly on the transformer. The transformer base plate is used to bolt the transformer to the chassis. The area around the transformer is open, enabling ample air flow from the two fans across the transformer. A thermistor is mounted directly to the transformer frame, enabling over-temperature monitoring. Output leads from the transformer, which go to other modules, are terminated in Mate-N-Lok connectors. A cable clamp is used to secure these leads to the chassis.

3.2.4 7009811-1, -2 AC Input Box

The ac input box is mounted in the center of the power supply chassis with three Phillips head screws. This enables easy access to the ac line cord, circuit breaker, and remote power control Mate-N-Lok. The 5410993 power control is physically mounted in the ac control box.

3.2.5 1211714 Box Fan

Two six-inch ball bearing fans, mounted in the chassis between the module boards and regulators, are utilized in the H765 power system. Each fan is secured to the chassis with two screws. The screws of each fan are tightened to 10 in./lb maximum.

3.2.6 5410864 Power Distribution Board

This power distribution board is a multilayer printed circuit board containing 12 Mate-N-Lok connectors connected directly to the board and four Mate-N-Loks connected to flying leads. The power distribution board is grounded using a ground tab which is connected to a flying lead. The power distribution board is mounted on the rear of the BA11-K chassis; four screws are used to fasten it in place.

3.3 SYSTEM FUNCTIONAL DESCRIPTION

A functional block diagram of the power system is shown in Figure 3-1. Assume that the line cord is plugged in and the circuit breaker is on; line voltage is applied to the ac input box. The ac input box contains a circuit breaker, relay, power control circuit, and regulator. The regulator, which is physically mounted in the ac input box, is functionally a separate assembly with its own part number. The circuit breaker can be used as an ON/OFF switch (only if pins 1 and 3 are shorted on the 3 pin connector) as well as an overcurrent protection device. The relay and power control circuit allows remote control of ac power to the transformer assembly by means of a key switch or thermal switch. The 7010014 transformer assembly steps down the voltage from the ac input box to approximately 28 Vdc and routes it to H744, H745, H754, and 5411086 regulators. In addition, the transformer assembly routes 115 Vac to box fans 1 and 2. The regulated dc outputs of the regulators are applied to the power distribution board, where they are distributed to the various backplane connections.

3.4 SYSTEM CIRCUIT DESCRIPTION

This paragraph describes, in detail, the ac input box, transformer assembly, regulators, and power distribution board. Figure 3-2 illustrates these circuits and their inter-relationship.

3.4.1 AC Input Box

The 115 V (7009811-1) and 230 V (7009811-2) ac input boxes are functionally identical. They differ physically in their components and in the way they are connected to the transformer assembly. Figure 3-3 is a simplified schematic of the 115 Vac power configuration. In this configuration, the power transformer windings are connected in parallel.

In the 230 Vac power configuration (Figure 3-4), the power transformer windings are connected in series. Remote capability of the ac input box is described in Paragraph 5.5.

Utilizing the 115 Vac input box (7009811-1), the input line voltage is applied via a 20 A circuit breaker (Figure 3-2) to relay K2, and transformer T1 on the power control board. Transformer T1 steps down the voltage to 24 Vac. The 24 Vac is rectified and applied to relay K1. To energize K1 (Figure 3-5), the remote power switch contacts must be closed. Energizing K1 completes the path to K2, switching the 115 Vac to the transformer assembly. The normally open thermal switch (TS1) (located in the transformer assembly) closes when an over-temperature condition is sensed. Closing TS1 applies 24 Vdc to half the K1 relay coil. This creates two opposing fields, causing K1 to deenergize. Deenergizing K1 interrupts the ac power to the transformer assembly. The varistor (D6 or D7) across the coil (Figure 3-2) of K2 suppresses voltage spikes in excess of 150 Vac for ac input box 7009811-1, and 275 Vac for ac input box 7009811-2.

3.4.2 Transformer Assembly

The primary function of the transformer assembly is to step down the 115 Vac or 230 Vac input voltage, (Figure 3-2) to 28 Vac. There are five separate secondary transformer windings, one for each regulator.

Connected across the primary of T1 are capacitors and varistors. The capacitors (C1, C2) are input line filters. The varistors (D1, D2) suppress voltage spikes in excess of 150 Vac. In addition, the transformer assembly routes 115 Vac from TB1 and TB2 to box fans 1 and 2, respectively.

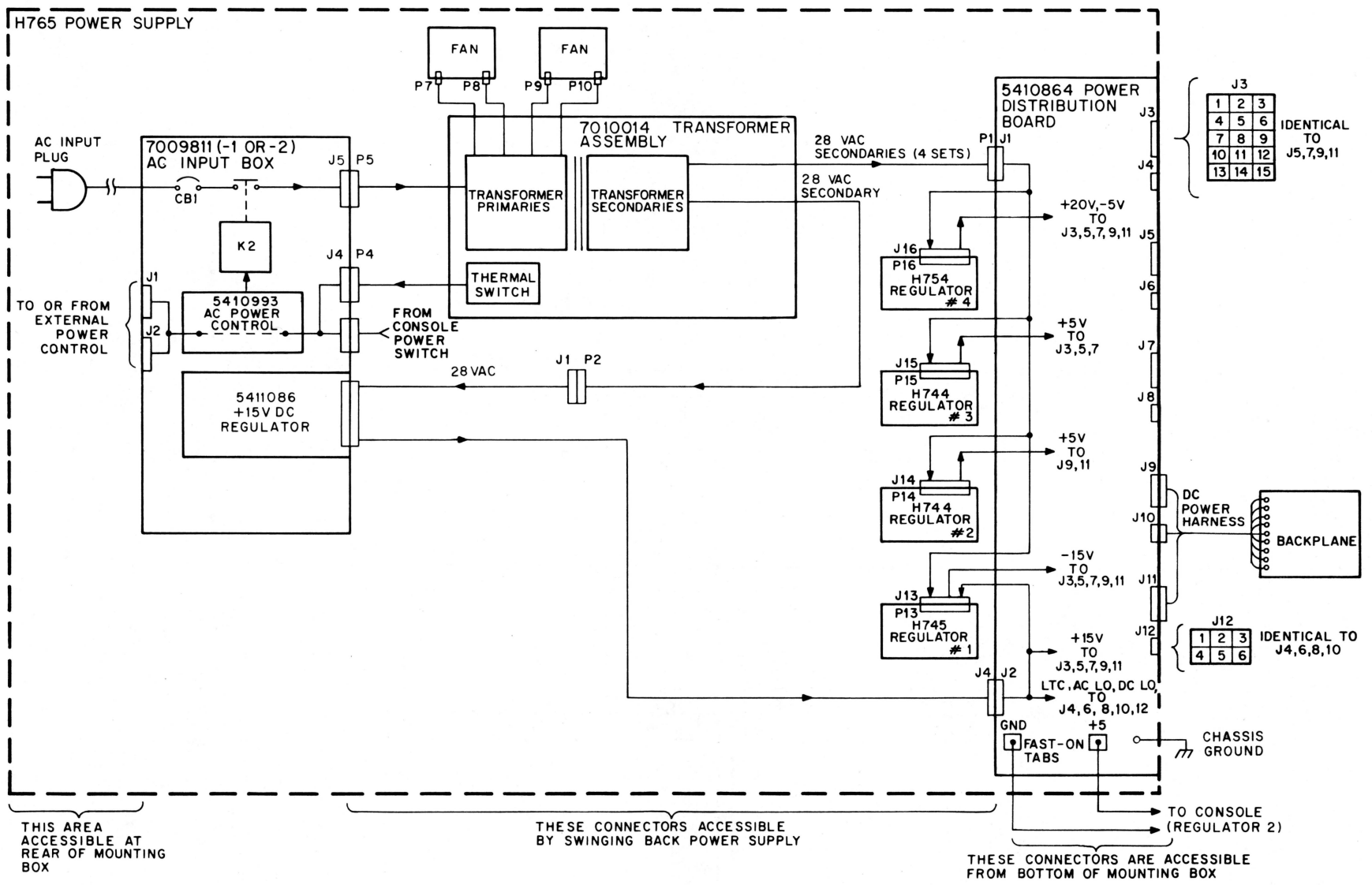

3-3

Figure 3-1 Power System Functional Block Diagram

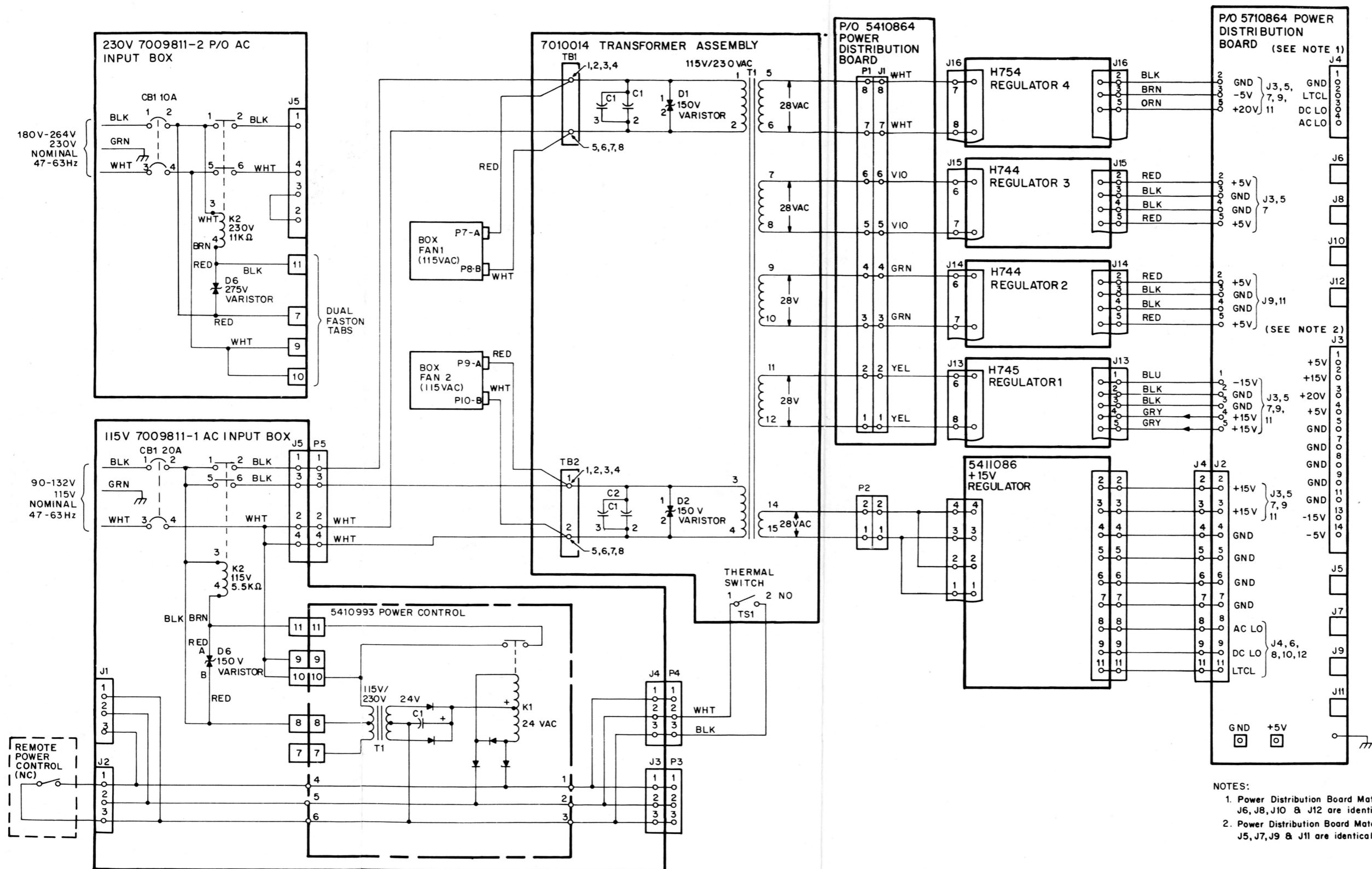

NOTES:
 1. Power Distribution Board Mate-N-Loks J6, J8, J10 & J12 are identical to J4
 2. Power Distribution Board Mate-N-Loks J5, J7, J9 & J11 are identical to J3

Figure 3-2 Power System Detailed Diagram

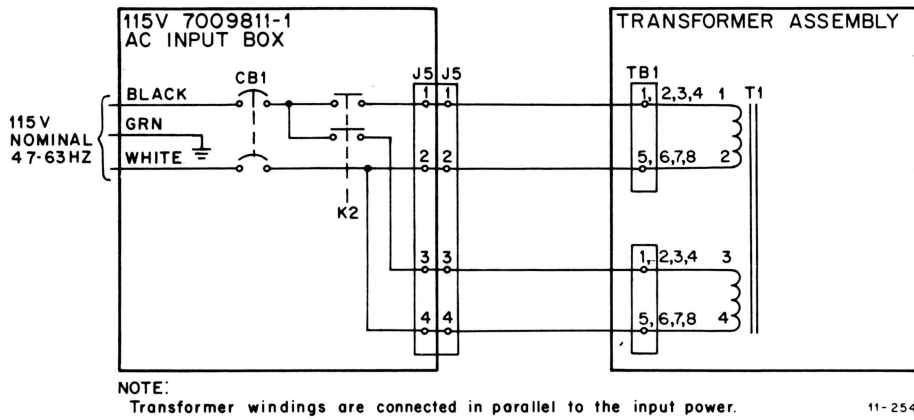

Figure 3-3 115 V Power Configuration

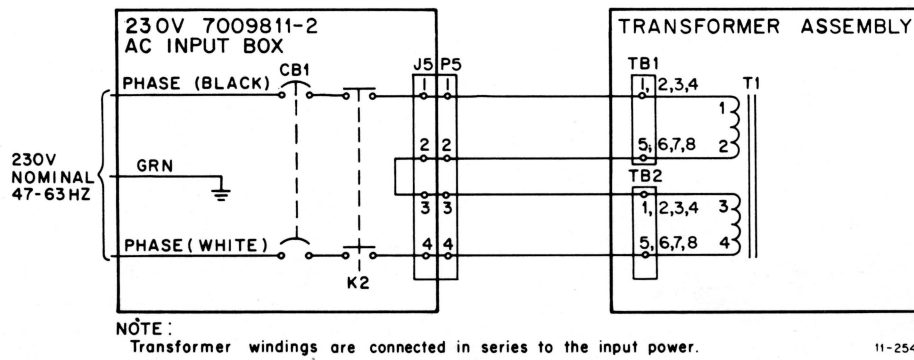

Figure 3-4 230 V Power Configuration

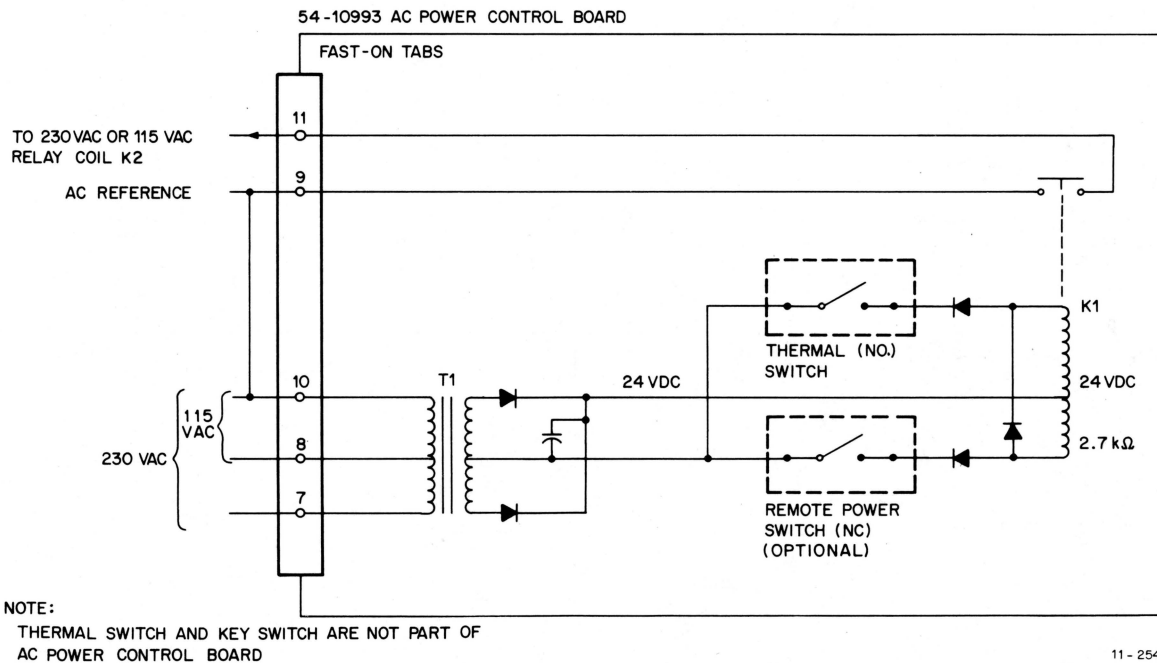

Figure 3-5 Power Control Simplified Diagram

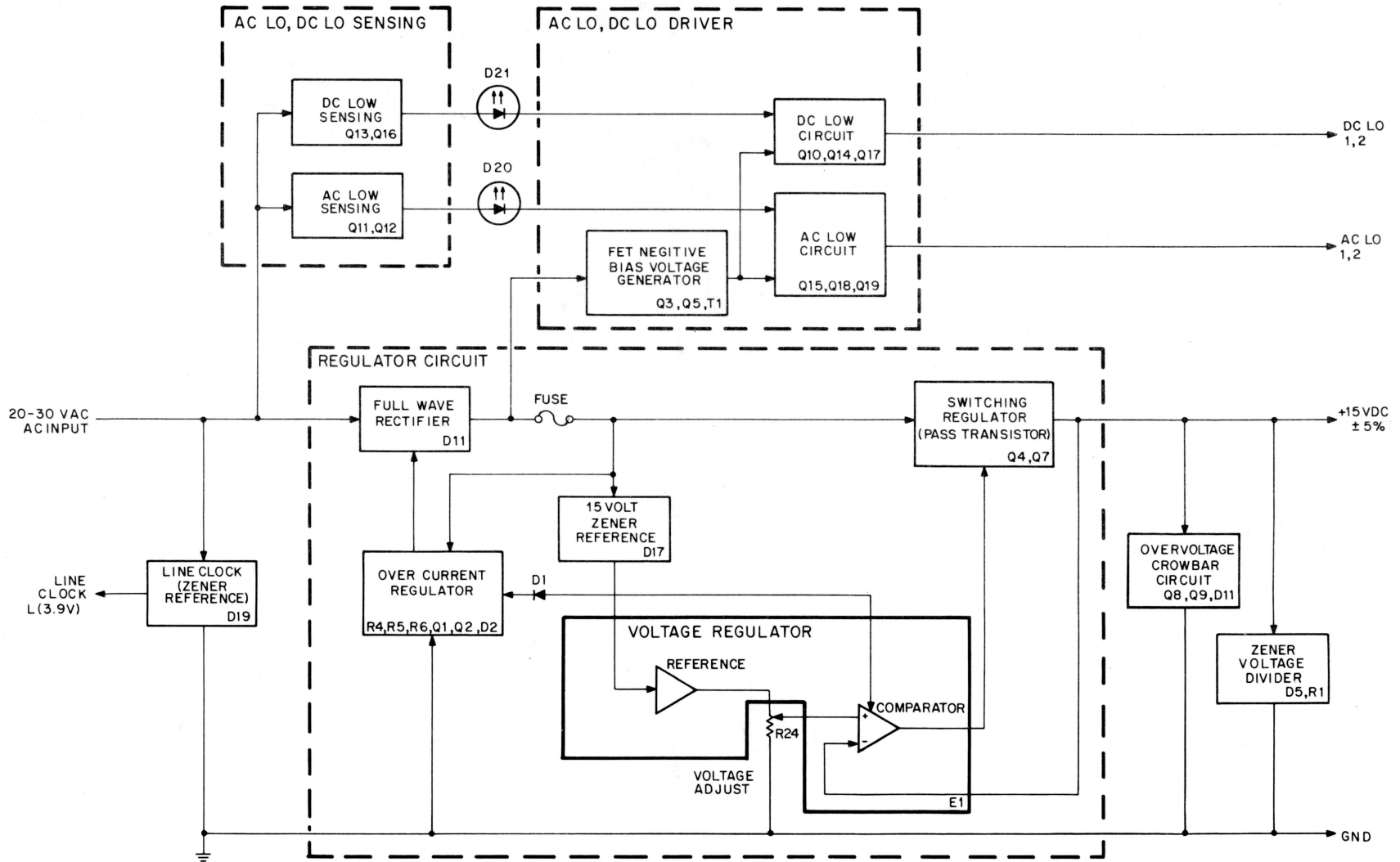

Figure 3-6 5411086 Block Diagram

3.4.3 5411086 Regulator

The 5411086 regulator (Figure 3-6) circuit schematic is shown on drawing D-CS-5411086-01. The following paragraphs describe the regulator circuit, overvoltage crowbar circuit, AC LO and DC LO sensing circuit, AC LO, DC LO drivers, and AC LO, DC LO indicators.

Regulator Circuit – The 20–30 Vac input is full-wave rectified by bridge D11 to provide dc voltage (25 to 45 Vdc, depending on line voltage and load on +15 V) across filter capacitor C1 and bleeder resistor R15. Operation centers on voltage regulator E1, which is configured as a positive switching regulator. A simplified schematic of E1 is shown in Figure 3-9. E1 is a monolithic integrated circuit that is used as a voltage regulator. It consists of a temperature-compensated reference amplifier, an error amplifier series pass power transistor, and the output circuit required to drive the external transistors. In addition to E1, the regulator circuit includes pass transistor Q7, predriver Q4, and level shifter Q6. Zener diode D17 is used with R11 to provide +15 V or E1.

The output circuit is standard for most switching regulators and consists of free-wheeling diode D12 choke coil L1, and output capacitor C3. These components make up the regulator output filter. Free-wheeling diode D12 is used to clamp the emitter of Q7 to ground when Q7 shuts off, providing a discharge path for L1.

In operation, Q7 is turned on and off, generating a square wave of voltage that is applied across D12 at the input of the LC filter (L1, and C10). Basically, this filter is an averaging device, and the square wave of voltage appears as an average voltage at the output terminal. By varying the period of conduction of Q7, the output (average) voltage may be varied or controlled, supplying regulation (Figure 3-7). The output voltage is sensed and fed back to E1, where it is compared with a fixed reference voltage. E1 turns pass transistor Q7 on and off according to whether the output voltage level approaches its upper and lower limits (approximately +15.15 V and +14.85 V respectively).

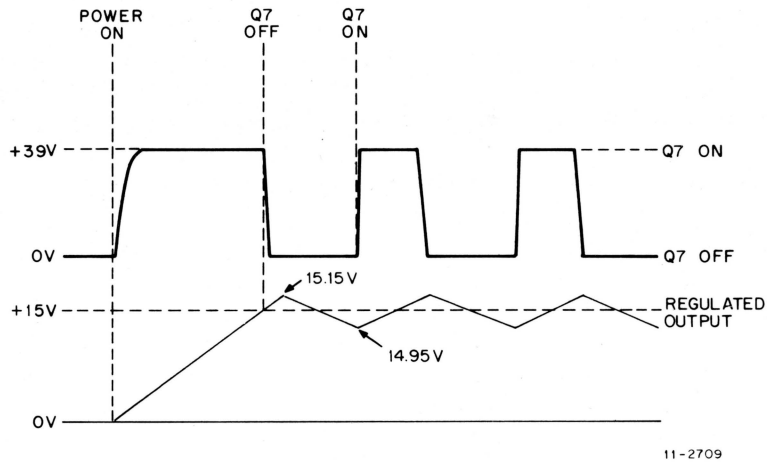

Figure 3-7 5411086 Regulator Waveforms

During one full cycle of operation, the regulator operates as follows: Q7 is turned on and a high voltage (approximately +30 V) is applied across L1. If the output is already at a +15 V level, then a constant +15 V would be present across L1. This constant dc voltage causes a linear ramp of current to build up through L1. At the same time, output capacitor C10 absorbs this changing current, causing the output level (+15 V at this point) to increase. When the output, which is monitored by E1, reaches approximately +15.15 V, E1 shuts off, turning Q7 off; the emitter of Q7 is then clamped to ground. L1 reverses polarity and discharges through D12 into capacitor C10, and the load. Predriver Q4 is used to increase the effective gain of Q7, ensuring that Q7 can be turned on and off in a relatively short period of time.

Conversely, once Q7 is turned off and the output voltage begins to decrease, a predetermined value of approximately +14.85 V will be reached, causing E1 to turn on; E1 in turn, causes Q7 to conduct, beginning another cycle of operation.

Thus, a ripple voltage is superimposed on the output and is detected as predetermined maximum (+15.15 V) and minimum (+14.85 V) values by E1. When +15.15 V is reached, E1 turns Q7 off; when +14.85 V is reached, E1 turns Q7 on. This type of circuit action is called a ripple regulator.

Overcurrent Regulator Circuit – The overcurrent regulator circuit functions as a current regulator when the current, monitored at D11, exceeds 5 A. The current regulator consists of R4, R5, R6, Q1, Q2, and D2. During normal operation Q1 and Q2 are not conducting. Q2 starts conducting when the voltage drop across R5 and R6 (sensed by D2) exceeds approximately 0.6 V. When Q2 conducts D1 becomes forward biased and E1 is shut off, turning off the pass transistor Q7 and predriver Q4. The conduction of Q2 will also turn on Q1 providing a constant current source (1 mA) to the base of Q2. Q1 will hold Q2 on until the current through R5 and R6 drops below approximately 4 A.

With Q1 and zener D2 tied to the +15 V zener reference for E1, the conduction of Q1 will hold E1 off. When Q1 and Q2 stop conducting, E1 will turn on, enabling the current to exceed the regulator limits. With a continuous condition Q1 and Q2 will be turning on and off, causing the circuit to become a constant current regulator.

+15 V Overvoltage Crowbar Circuit – The following components comprise the overvoltage crowbar circuit: Zener diode D18, silicon-controlled rectifier (SCR) Q8, Q9, R38, R40, and C13. Under normal output voltage conditions, the trigger input to SCR D7 is at ground because the voltage across zener diode D3 is less than 18 V. If the output voltage becomes dangerously high (above 18.0 V), diode D18 conducts turning Q9 on, and the voltage drop across R40 draws gate current and triggers the SCR. The SCR fires, short circuits the +15 V output to ground, and turns off E1 by shorting out the +15 V reference at D17.

Line CLOCK Output – The CLOCK output is generated by one leg of full-wave rectifier bridge D11, voltage divider R22, and zener diode D19. The CLOCK output is a 0 to +3.9 V square wave, at the line frequency of the power source (47 to 63 Hz). The CLOCK output is used to drive the KW11-L line frequency and KW11-P real time clock options.

AC LO and DC LO Sensing – The 20–30 Vac input from the secondary of transformer T1 is applied to the AC LO and DC LO sensing circuits shown on drawing D-CS-5411086-0-1. The ac input is rectified by diodes D15 and D16, and filtered by capacitors C20 and C24. A common reference voltage is derived by zener diodes D13 and D14. Both sensing circuits operate similarly; each contains a differential amplifier and associated circuits. The major difference is that the base of Q12 in the AC LO circuit differential amplifier is at a slightly lower value than that of Q16 in the DC LO differential amplifier. The operation of both sensing circuits depends on the voltage across capacitor C8. For AC LO and DC LO timing during power up and power down, refer to Figure 3-8.

AC LO and DC LO Driver – When an ac low condition is sensed, the output of differential amplifier Q12 turns off Q19. Q19 in turn, gates on fets Q15 and Q18, generating AC LO 1 and AC LO 2 signals (Figure 3-8). Approximately 7 ms after ac low is sensed, the dc low sensing circuit will generate dc low. The dc low sensed output from differential amplifier Q16, turns off Q10. Q10 in turn gates on fets Q14 and Q17, generating DC LO 1 and DC LO 2 signals (Figure 3-8).

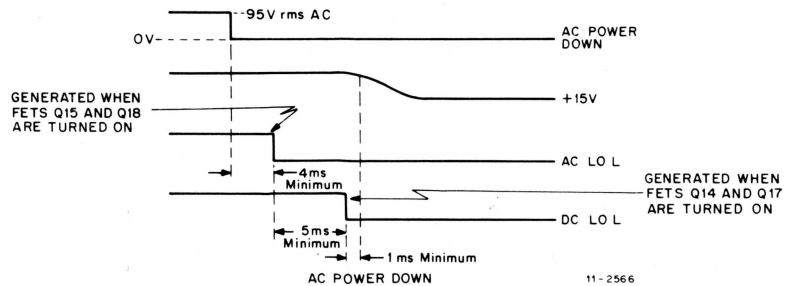
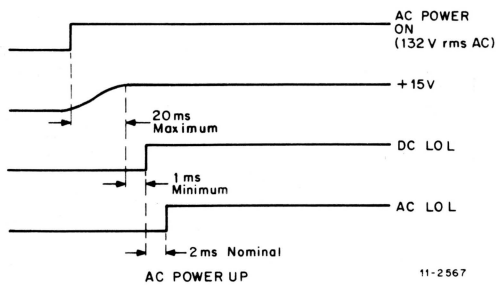

Figure 3-8 5411086 Power Up and Power Down

The +25 Vdc to +45 Vdc from rectifier D11 is applied to T1, Q3, and Q5. Q3 and Q5 due to their switching action creates a pulsating dc which is applied to the primary of transformer T1. The output from the secondary of T1 (approximately 15 V) is rectified by D6, D7, D8, and D9, producing -10 Vdc to -15 Vdc. The -10 Vdc to -15 Vdc is negative bias used to gate OFF J FETs Q15, Q18, Q14, and Q17 via Q19 and Q10. Unlike most transistors the negative bias is used to turn off the J FETs. The J FETs are turned on when there is zero volts between gate (G) and source (S) terminals.

AC LO and DC LO Indicators – Light-emitting diodes D20 and D21 are normally lit. When AC LO L and DC LO L are asserted, the light-emitting diodes go off, indicating that this regulator is the source of AC LO L or DC LO L on the Unibus.

3.4.4 H744 +5 V Regulator

Two H744 +5 V regulators are used in the basic H765 power system. The H744 circuit schematic is shown in drawing D-CS-H744-0-1. The following paragraphs describe the regulator circuit, overcurrent sensing circuit, and overvoltage crowbar circuit.

Regulator Circuit – The 20–30 Vac input is full-wave rectified by bridge D1 to provide dc voltage (24 to 40 Vdc, depending on line voltage) across filter capacitor C1 and bleeder resistor R1. Operation centers on voltage regulator E1, which is configured as a positive switching regulator. A simplified schematic of E1 is shown in Figure 3-9. E1 is a monolithic integrated circuit that is used as a voltage regulator. It consists of a temperature-compensated reference amplifier, an error amplifier series pass power transistor, and the output circuit required to drive the external transistors. In addition to E1, the regulator circuit includes pass transistor Q2, predrivers Q3 and Q4, and level shifter Q5. Zener diode D2 is used with Q5 and R2 to provide +15 V for E1. Q5 is used as a level shifter; most of the input voltage is absorbed across the collector-emitter of Q5. This is necessary because the raw input voltage is well above that required for E1 operation. While this +15 V input is supplied, D2, Q5, and R2 retain the ability to switch pass transistor Q2 on or off by drawing current down through the emitter of Q5.

The output circuit is standard for most switching regulators and consists of free-wheeling diode D5, choke coil L1, and output capacitors C8 and C9. These components make up the regulator output filter. Free-wheeling diode D5 is used to clamp the emitter of Q2 to ground when Q2 shuts off, providing a discharge path for L1.

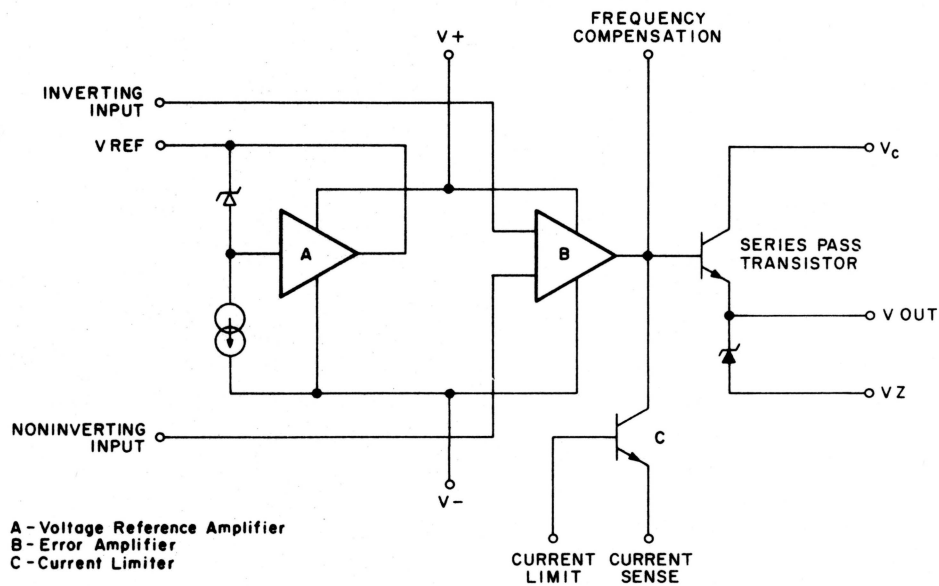

Simplified Schematic

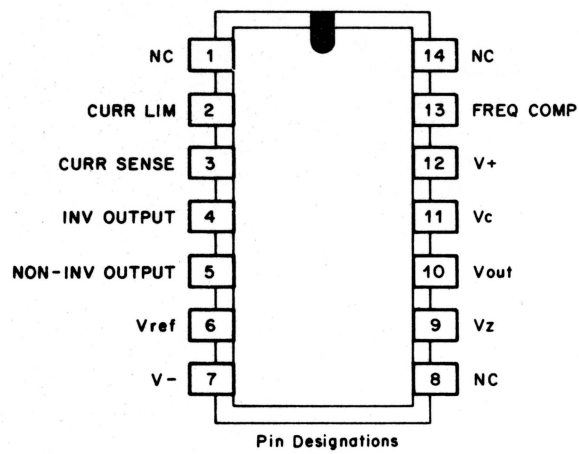

11-1895

Figure 3-9 Voltage Regulator E1, Simplified Diagram

3.4.5 H745 -15 V Regulator

Operation of the H745 is basically the same as that of the +5 V regulator (drawing D-CS-H745-0-1). Input power (20 to 30 Vac) is taken from the transformer secondary and input to full-wave bridge D1, whose output is a variable 24 to 40 Vdc input across capacitor C1 and resistor R1.

-15 V Regulator Circuit – Regulator operation is almost identical to that of the +5 V regulator; however, the +15 V input that is required for E1 operation is derived externally and is input across capacitor C2 to +1, and the inverting and noninverting inputs to E1 are reversed. In addition, the polarities of the various components are reversed. For example, Q5, which is used as a “level shifter,” is an NPN transistor on the +5 V regulator; a PNP is required on the -15 V regulator to allow the regulator to operate below ground (at -15 V).

Under normal operating conditions, regulator operation centers around linear regulator E1 and pass transistor Q2, which is controlled by E1. Predetermined output voltage limits are -14.85 V minimum and -15.15 V maximum. When the output reaches -15.15 V, E1 will shut off, turning Q2 off, and L1 discharges into C8 and C9. When the output reaches -14.85 V, E1 will conduct, causing Q2 to turn on, thereby increasing the output voltage.

-15 V Overcurrent Sensing Circuit – The -15 V regulator overcurrent sensing circuit is basically made up of the same components used in the +5 V regulator, except Q1 is an NPN transistor in the -15 V regulator. Q1 is normally not conducting; however, once the output exceeds 15 A, Q1 will turn on and C3 will charge. When C3 reaches the same value as the gate of Q7, E1 will be biased off, turning Q2 off, and thereby stopping current flow and turning the -15 V regulator off. Thus, the regulator is short circuit protected.

-15 V Overvoltage Crowbar Circuit – When SCR D5 is fired, the -15 V output is pulled up to ground and latched to ground until input power or the +15 V input is removed. A negative slope on the +15 V line can be used to trip the crowbar for power down sequencing, if desired.

3.4.6 H754 +20, -5 V Regulator

One H754 regulator is used in the basic H765 power supply. The H754 circuit schematic is shown in drawing D-CS-H754-0-1. The following paragraphs describe the regulator circuit, overvoltage crowbar circuits, overcurrent sensing circuits, and voltage adjustment procedure.

Regular Circuit – The circuit (schematic D-CS-H754-0-1) has a voltage doubler input, but the output consists of two shunt regulator circuits – one for the +20 V, the other for

the -5 V. The +20 V shunt regulator consists of transistors Q4, Q10, and Q11; the -5 V shunt regulator consists of Q6 and Q9. Q10 and Q9 are the pass transistors.

The output of the basic regulator is 25 V (-5 to +20 V). The shunt regulators are connected across this output, with a tap to ground between pass transistors Q9 and Q10. The voltage at the bases of Q6 and Q4 will vary with respect to ground, depending on the relative amount of current drawn from the +20 V and -5 V outputs of the regulator. If the +20 V current increases while the -5 V current remains constant, the output voltage at the +20 V output will tend to go more negative with respect to ground; this will also cause the -5 V output to go more negative, since the output of the basic regulator is a fixed 25 V. This change is sensed at the bases of Q6 and Q4: Q6 will conduct, causing Q9 to conduct also, increasing the current between -5 V and ground until the balance between the +20 V and the -5 V is restored. At this time, neither Q6 nor Q4 will be conducting. If the -5 V current increases, Q4 and Q10 will conduct to balance the outputs.

Overvoltage Crowbar Circuits – There are two crowbar circuits in the H754: Q7 and its associated circuitry for the +20 V, and Q12 and its circuitry for the -5 V. Either one will trigger SCR D9.

Overcurrent Sensing Circuit – The overcurrent circuit comprises Q1, Q8, Q13, Q14, and associated circuitry. The total peak current is sampled through R4. When the peak current reaches approximately 14 A, Q1 turns on sufficiently to establish a voltage across R7 and R38, firing Q8. This pulls the voltage on pin 4 of the 723 up above the reference voltage on pin 5, shutting off Q2. D6 now conducts, and the current through R37 turns on Q14, which turns on Q13. This keeps Q8 on for a time which is determined by the output voltage and L1. This action, in turn, allows the off-time to increase as the overload current increases, thereby changing the duty cycle in proportion to the load. The output current is thus limited to approximately 10 A.

Voltage Adjustment – The +20 V adjustment is located on the side of the H754; the -5 V potentiometer is on the top, next to the connector. To set the output voltages, power down, disconnect the load, power up, and adjust for a 25 V reading between the +20 and -5 V outputs with the 20 V potentiometer. Then set the -5 V between its output and ground. Power down, reconnect the load, power up, and then check and adjust the outputs again. This procedure is necessary because the +20 V potentiometer (R17) actually sets the overall output of the regulator (25 V from +20 V to -5 V), while the -5 V adjustment (R21) controls the -5 V to ground output. (See schematic drawing D-CS-H754-0-1.)

MATE-N-LOKS J11, J9, J7, J5, J3

PIN DESIGNATIONS				
13	10	7	4	1
14	11	8	5	2
15	12	9	6	3

PIN	SIGNAL
1.	+ 5V
2.	+ 15V
3.	+ 20V
4.	+ 5V
5.	GROUND
6.	Not Used
7.	GROUND
8.	GROUND
9.	GROUND
10.	Not Used
11.	GROUND
12.	Not Used
13.	- 15V
14.	- 5V
15.	Not Used

MATE-N-LOKS J12, J10, J8, J6, J4

PIN DESIGNATIONS	
4	1
5	2
6	3

PIN	SIGNAL
1.	GND
2.	LTC (Line Clock)
3.	DC LO
4.	AC LO
5.	Not Used
6.	Not Used

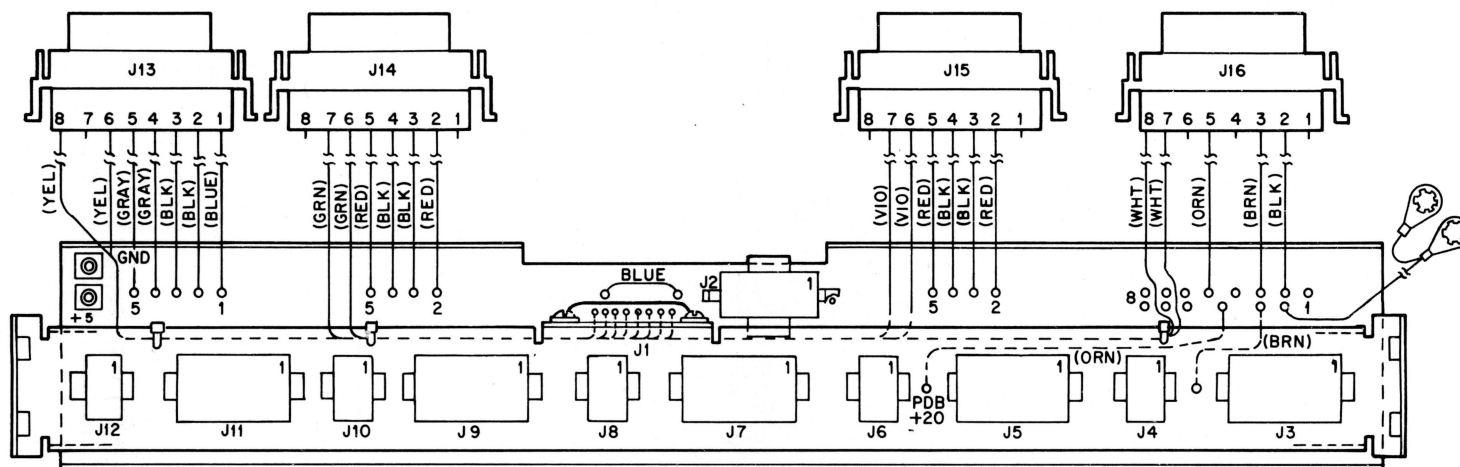

11-2570

Figure 3-11 Power Distribution Board

3.4.7 Power Distribution Board

The power distribution board (Figure 3-11) performs two primary functions: It routes the transformer assembly secondary output voltages to the regulators and routes the dc outputs of the regulators to the backplane.

Routing voltage to the regulators is accomplished via Mate-N-Lok J1/P1 and an etch on the power distribution board. Mate-N-Lok P1/J1 routes 28 Vdc from four separate transformer secondaries to H745, H754, and both H744 regulators. The etch routes +15 Vdc from 5411086 regulator to the H745 regulator.

The regulator outputs are routed as follows:

H745 Regulator 1: -15 Vdc output is routed via the power distribution board etch to 15-pin Mate-N-Loks J3, J5, J7, J9, and J11.

H744 Regulators 2 and 3: Regulator 2 +5 Vdc output is routed via the power distribution board etch to 15-pin Mate-N-Loks J9 and J11. H744 regulator 3, +5 Vdc output is routed via the power distribution board etch to 15-pin Mate-N-Loks J3, J5, and J7. A unique configuration of the power system is that two H744 regulators cannot be connected in parallel. Figure 3-12 is a simplified diagram illustrating the correct H744 to power distribution board configuration.

H754 Regulator 4: +20 Vdc and -5 Vdc outputs are routed via the power distribution board etch to 15-pin Mate-N-Loks J3, J5, J7, J9, and J11.

5411086 Regulator: +15 Vdc output is routed via the power distribution board etch to H745. The +15 Vdc is also routed via the etch to 15-pin Mate-N-Loks J3, J5, J7, J9, and J11. 5411086 LTC, AC LO L, and DC LO L outputs are routed via the etch to 6-pin Mate-N-Loks J4, J6, J8, J10, and J12.

The dc and signal outputs of Mate-N-Loks J3 through J12 are routed to the backplane via a power harness. Tables 2-4 and 2-5 list the power harnesses required for the appropriate option.

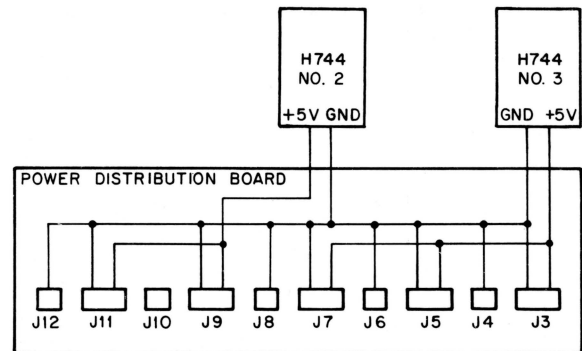

NOTE:

Regulators H745, H754, and 5411086 output voltages are common to MATE-N-LOKS J3, J5, J7, J9, and J11.

11-2565

Figure 3-12 H744 Connection Diagram

CHAPTER 4 MAINTENANCE

BA11-K maintenance procedures are divided into two categories: Preventive maintenance and corrective maintenance. Corrective maintenance should be performed to isolate a fault or malfunction and to make necessary adjustments and/or replacements. Diagnostic programs that test the functional units of the system and special calibration and test procedures aid in performing corrective

maintenance. This chapter describes the equipment and procedures needed for performing corrective and preventive maintenance.

4.1 MAINTENANCE EQUIPMENT REQUIRED

Maintenance procedures for the BA11-K require the standard equipment (or equivalent) listed in Table 4-1.

**Table 4-1
Field Service Maintenance Equipment Required**

Equipment or Tool	Manufacturer	Model, Type, or Part No.	DEC Part No.
Oscilloscope	Tektronix	453 (or equivalent)	29-13510
DVM	—	—	—
Volt/ohmmeter (VOM)	Triplet	—	29-13510
Diagonal cutters	Utica	47-4	29-13460
Diagonal cutters	Utica	466-4 (modified)	29-19551
Miniature needle-nose pliers	Utica	23-4-1/2	29-13462
Wire strippers	Millers	101S	29-13467
Solder extractor	Solder Pullit	Standard	29-13451
Soldering iron (30 W)	Paragon	615	29-13452
Soldering iron tip	Paragon	605	29-19333

4.2 PREVENTIVE MAINTENANCE

4.2.1 General

Preventive maintenance consists of specific tasks performed periodically to prevent failures caused by minor damage or progressive deterioration due to aging. A preventive maintenance log book should be established and necessary entries made according to a regular schedule. This data, compiled over an extended period of time, can be very useful in anticipating possible component failure.

Preventive maintenance tasks consist of mechanical and electrical checks. All maintenance schedules should be established according to environmental conditions at the particular installation site. Mechanical checks should be performed as often as required to enable fans and air filters (if applicable) to function efficiently. All other preventive maintenance tasks should be performed on a regular schedule determined by reliability requirements. A recommended schedule is every 1000 operating hours or every three months, whichever occurs first.

4.2.2 Physical Checks

The following is a list of the steps required for mechanical checks and physical care of the BA11-K.

1. Check all fans to ensure that they are not obstructed in any way.
2. Inspect all wiring and cables for cuts, breaks, frays, deterioration, kinks, strain, and mechanical security. Repair or replace any defective wiring or cable covering.

3. Inspect the following for mechanical security: Lamp or LED holder assemblies, jacks, connectors, switches, power supply regulators, fans, capacitors, etc. Tighten or replace as required.
4. Inspect power supply capacitors for leaks, bulges, or discoloration. Replace as required.

4.3 MAINTENANCE PROCEDURE

4.3.1 H765 Power System Fault Isolation

The H765 power system (Figure 3-2) consists of field replaceable modules. Once a power system failure is discovered, the following steps and associated flowchart (Figure 4-1) can be utilized to isolate to a faulty module:

1. Ensure that the H765 is plugged in and getting primary ac power (115 Vac/230 Vac).
2. Check CB1 on the ac input box.
3. Utilizing the flowchart (Figure 4-1) and H765 power system schematic (Figure 3-2), isolate the faulty module.
4. Replace the module as described in Paragraph 4.4.
5. When a fault is isolated to a voltage regulator, refer to Paragraphs 4.3.2–4.3.4 for voltage regulator checks and adjustments.

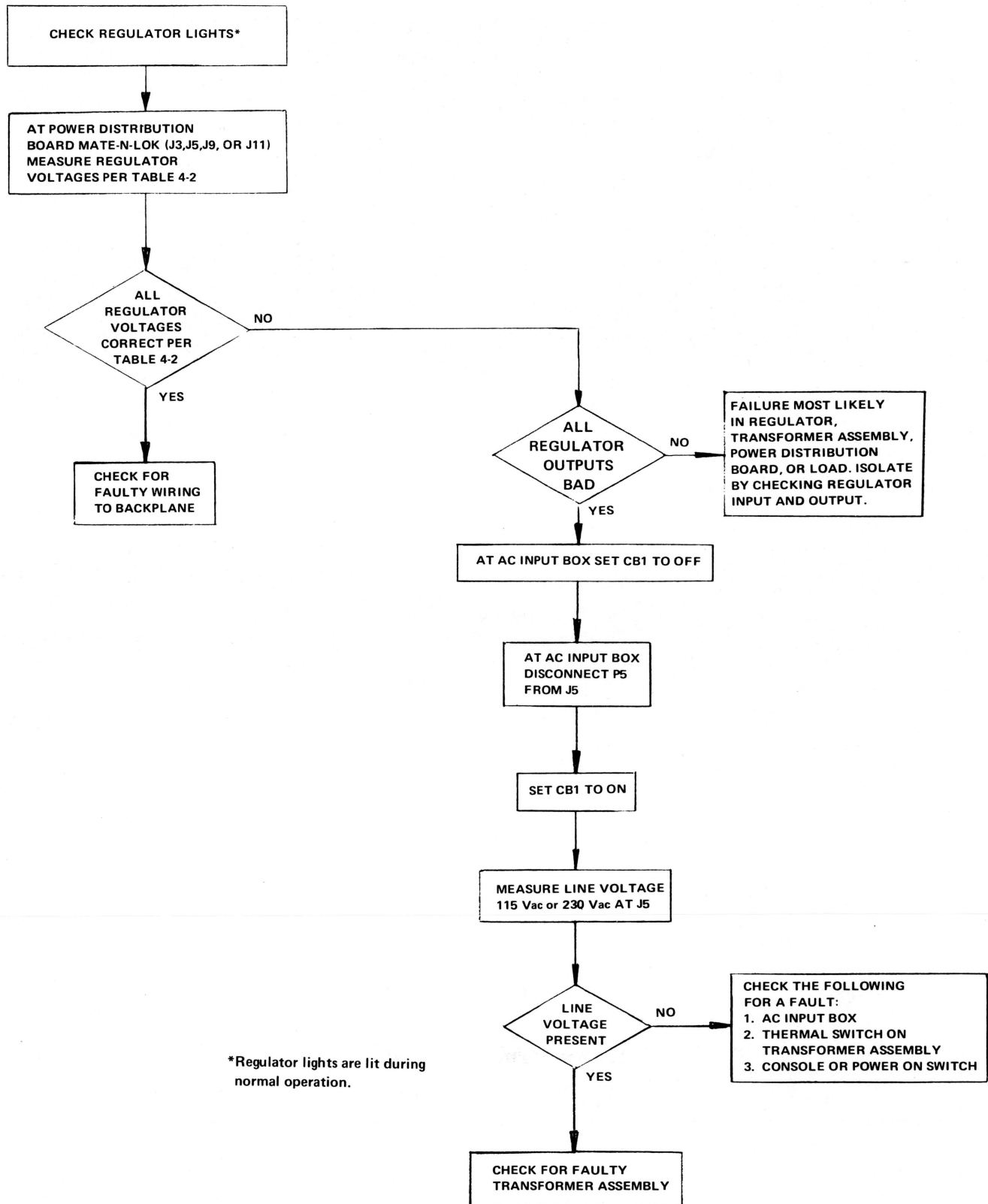

*Regulator lights are lit during normal operation.

Figure 4-1 H765 Fault Isolation Flowchart

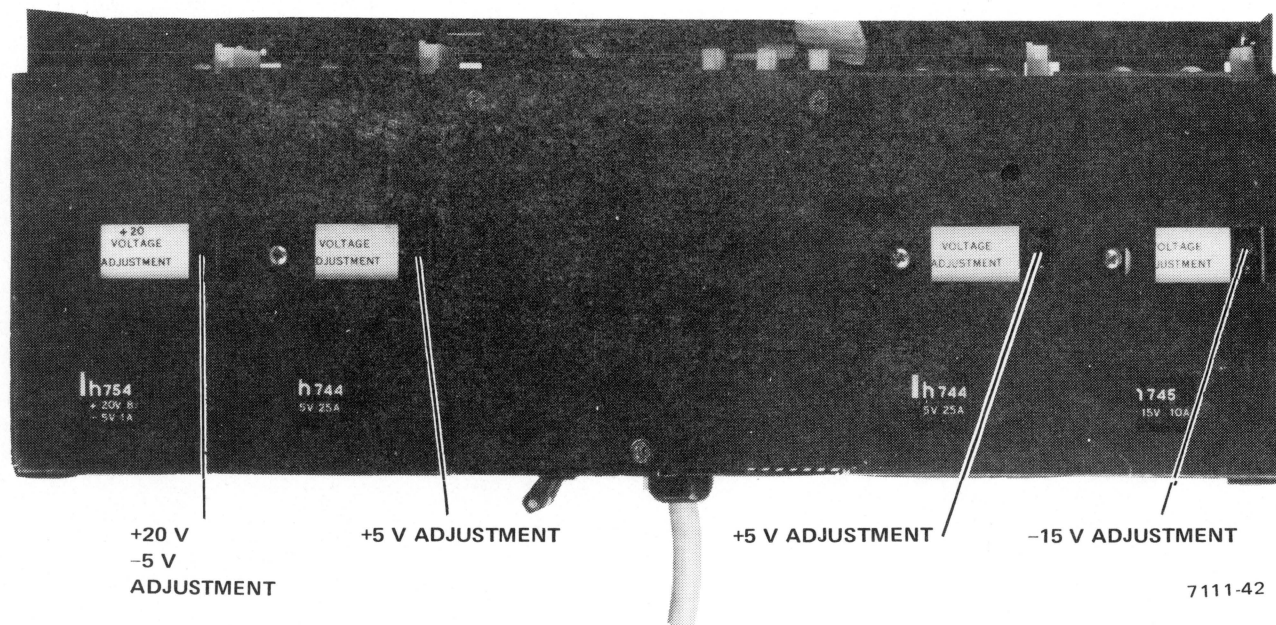

Figure 4-2 Regulator Adjustments

Table 4-2
Regulator Specifications

Regulator	Voltage and Regulation at Backplane	Maximum Voltage at Regulator (Note 1) (Vdc)	Maximum Output Current (A)	Maximum Peak-to-Peak Ripple
H744	+5 Vdc \pm 250 mV	5.5	25	200 mV
H745	-15 Vdc \pm 750 mV	16	10	450 mV
H754	+20 Vdc \pm 1 V	21.5	8	5% } (Note 2) 5% }
(Note 4)	-5 Vdc \pm 250 mV	5.5	1-8 (Note 3)	
5411086	+15 Vdc \pm 10%	-	4	3%

- Notes:
1. Do not adjust the regulator to these voltages. They represent the maximum regulator voltage prior to crowbar.
 2. At backplane. Typical ripple \approx \pm 3%.
 3. Maximum -5 V current is dependent upon +20 V current. It is equal to 1 A plus the current of the +20 V supply up to a total of 8 A.
 4. When adjusting the output of H754, adjust +20 Vdc first, then -5 Vdc (Paragraph 3.4.6).

4.3.2 Voltage Regulator Checks and Adjustments

Correct power system voltages at the backplane are critical to a properly operating system. The power system voltages are supplied by the regulators listed in Table 4-2. Each voltage regulator has an adjustment potentiometer (Figure 4-2). The H744, H745 and H754 adjustment potentiometers are located next to the output lamp. Perform the following steps to ensure that the voltages are within tolerance. If a voltage regulator cannot be adjusted to meet the tolerance, check for a bad regulator, power distribution board, or wiring.

1. Using a DVM, measure the output voltages under normal load conditions at the backplane (Table 4-2).
2. Adjust voltages at the backplane to the tolerances specified in Table 4-2, as required.
3. Using a DVM, measure the voltage at the regulator (or power distribution board). Ensure that the maximum voltages at the regulator

(Table 4-2) are not exceeded. These voltages represent the maximum regulator voltage prior to crowbar. (Do not adjust the regulator to these voltages.)

4. Using an oscilloscope, measure the peak-to-peak ripple content on all dc outputs (Table 4-2).

4.3.3 Voltage Regulator Troubleshooting

The voltage regulators in the H765 power system are designed to be replaced when a failure is detected. However, there are unique situations when a regulator must be repaired in the field. Table 4-3 lists the primary fault indications, the most probable cause, and corrective action required. This table should be used in conjunction with the regulator's theory of operation (Chapter 3) and the print set.

Once the repairs have been accomplished or a new regulator is installed (Paragraph 4.4.8), refer to Paragraph 4.3.2 for voltage regulator checks and adjustments.

Table 4-3
H744, H745, H754 Voltage Regulator Troubleshooting Chart

Fault Indication	Most Probable Cause	Corrective Action
No output voltage	<ol style="list-style-type: none"> 1. D1 (bottom of D1 will appear burnt). 2. E1 (DEC 723, IC voltage regulator). 3. Misadjusted output voltage. 	<p>Replace regulator or D1.</p> <p>Replace regulator or E1 (Figure 3-9).</p> <p>Shut power off and turn voltage adjust fully ccw (below crowbar voltage). Turn power on and slowly increase voltage, per Table 4-2, until correct value is obtained.</p>
Blown fuse	<ol style="list-style-type: none"> 1. Q2 (pass transistor). 2. Excessive loading of voltage regulator. 	<p>Replace voltage regulator or pass transistor and associated components.</p> <p>Replace fuse and check loads.</p>

4.3.4 Regulator Bench Test Procedures (H744, H745, and H754)

This paragraph suggests procedures to troubleshoot and test the H744 +5 V regulator, H745 -5 V regulator, and H754 +20 V, -5 V regulator modules. The procedures are intended to aid in locating a fault, provided the fault has not destroyed the etched circuits.

When replacing a faulty voltage regulator, the new voltage regulator may need adjustment to compensate for the load. If the new regulator is initially adjusted too high, it may activate the crowbar circuit and provide no output when initially installed. If this happens, turn power off and rotate the adjustment potentiometer counterclockwise. Then re-apply power (regulator should not crowbar) and adjust the regulator output.

4.3.4.1 Initial Tests – When a power system fault has been isolated to a voltage regulator (H744, H745, or H754), examine internal fuse F1. A blown fuse usually indicates that the main pass transistor Q2 and/or one of its drivers, Q3 or Q4, has short circuited.

1. Check for damage to base-emitter bleeder resistors and a scorched etched board in the area of Q3 (and Q4 if applicable).
2. If the pass transistor and drivers check OK on a VOM, the fault may be caused by continuous base drive to the first driver, Q4 (Q3 in H754). Check level shifter Q5 for a short circuit.
3. Check the resistance to ground at the input to precision voltage regulator integrated circuit E1 (pins 4 and 5) to determine if an external short circuit is affecting the IC.
4. Use the VOM to check for a short circuit between fuse terminals and ground. Possible short circuits involving mounting TO-3 components to the heat sink may be located by connecting VOM leads between TO-3 cases and a regulator bracket mounting screw on the end of the heat sink.

4.3.4.2 Output Short Circuit Tests – A voltage regulator that provides no output or low output without causing fuse F1 to blow, is probably working into a short-circuited output.

NOTE

An activated crowbar or a short-circuited output in an otherwise properly operating voltage regulator will not cause F1 to blow.

1. If fuse F1 is not blown and the area of etched circuit around the ac input to the bridge circuit is not damaged, it is safe to apply an ac input to the voltage regulator to determine if the regulator is overloaded by a short circuit across the output.
2. Connect the voltage regulator to a test bench source and advance the Variac to about 90 V (20 Vac at voltage regulator input). If the output is near 0 V, turn the voltage adjustment fully counterclockwise and repeat the test.
3. If the regulator appears overloaded, check for a short circuit across the output and for a component failure in the crowbar circuit.

4.3.4.3 Testing a “Dead” Regulator – Use the following procedure to test a faulty regulator that does not exhibit the symptoms described above.

1. Apply 115 Vac to the test bench source (25 Vac at the voltage regulator input), with no load on the regulator output.
2. Check for 30 Vdc across filter capacitor C1 (and C2 if applicable).
3. Check for +15 Vdc at pin 12 of precision voltage regulator E1. No voltage at this point could mean zener diode D2 (H744) or D3 (H754) has failed.
4. Check for 6.8–7.5 Vdc at pin 6 of E1 with respect to ground, pin 7.
5. If all voltage measurements steps 2, 3, and 4 are OK and there is no output voltage, pin 5 of E1 should be positive with respect to pin 4.

E1, pin 2, should be +0.6 V with respect to pin 3. If it is not, connect the emitter and base of Q5. If a 0.6 V indication is obtained, precision voltage regulator E1 is OK and the fault is probably caused by Q5 or Q4 (Q3 in H754).

4.3.4.4 Testing a Voltage Regulator After Repairs – Before returning a repaired voltage regulator to service, it should be checked as follows:

1. Connect the repaired voltage regulator to the appropriate source connector.
2. Set the voltage adjustment fully counterclockwise and set the load to zero.
3. Close the input circuit breaker and advance the Variac until output voltage is indicated (at approximately 60–80 Vac input). No audible noise should be heard under no-load conditions.
4. Be sure Q2 is connected and soldered before loading the regulator.

5. Advance the Variac to 130 Vac and return to 115 Vac.
6. Apply a 30–50 percent load. The output voltage should remain nearly constant. A clean whistle may be heard. A buzz or harsh hissing sound indicates possible instability. Check waveforms as indicated in Figure 4-3.
7. Apply 100 percent load and set the voltage adjustment for nominal output as listed:

H744	+5.10 Vdc
H745	-15.10 Vdc
H754	+25 Vdc between +20 and -5 V outputs

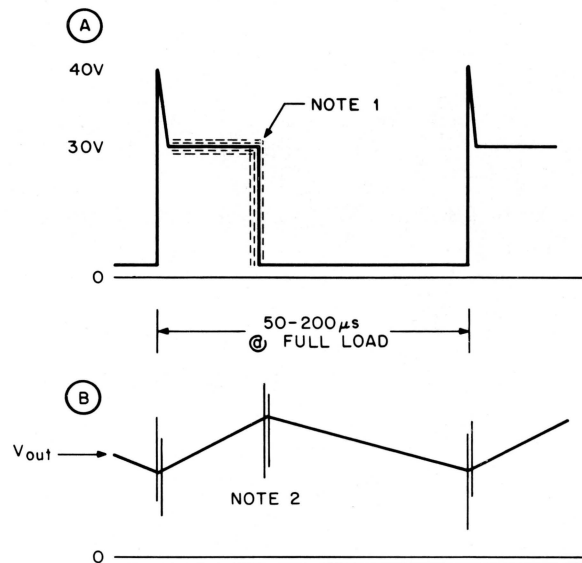
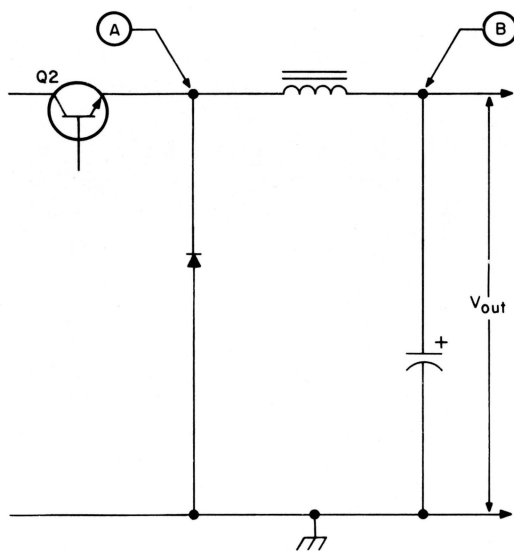

NOTE 1: 30 volt level shifts with AC input voltage. Small 120Hz jitter is normal.

NOTE 2: Peak noise=1% max.

Measure noise with a short 100Ω terminated piece of foil coax. Normal 10:1 scope probe will not give an accurate noise measurement.

11-1075

Figure 4-3 Typical Voltage Regulator Output Waveforms

8. Apply 200 percent load and check for a decrease in the frequency and the output voltage.

CAUTION

If the output voltage does not decrease noticeably (approximately 1 V on H744, or 1 to 5 V on the H745 and H754), do not attempt the following short circuit test.

9. Short circuit the output. The regulator should continue to operate at a low frequency with a clean, smooth whistle and stable waveforms.
10. Increase the voltage adjustment and observe the output voltage when the crowbar circuit fires. The output voltage should be within the following ranges:

H744	6.00–6.65 V
H745	16.8–20.5 V
H754	25.0–30.0 V and –6.00 to –7.00 V

4.4 H765 POWER SYSTEM SUBASSEMBLY REMOVAL PROCEDURE

4.4.1 Introduction

The H765 power system access procedure enables the H765 to be accessed for adjustments and subassembly removal.

The removal procedures include:

1. H765 power system access procedure.
2. H744, H745, and H754 regulator removal.
3. AC power input box and 5411086 regulator removal.
4. Fan removal.
5. Transformer assembly removal.
6. Power distribution board removal.

4.4.2 H765 Power System Access Procedure (Figure 4-4)

1. Remove ac power by disconnecting the ac line cord from the ac power source.
2. Fully extend the BA11-K from the rack, ensuring that cables do not bind.
3. Remove the BA11-K's top cover by removing six screws.
4. Remove the cable clamps by removing four screws.
5. To remove the H765's top cover, loosen the top three screws and remove the back four screws.

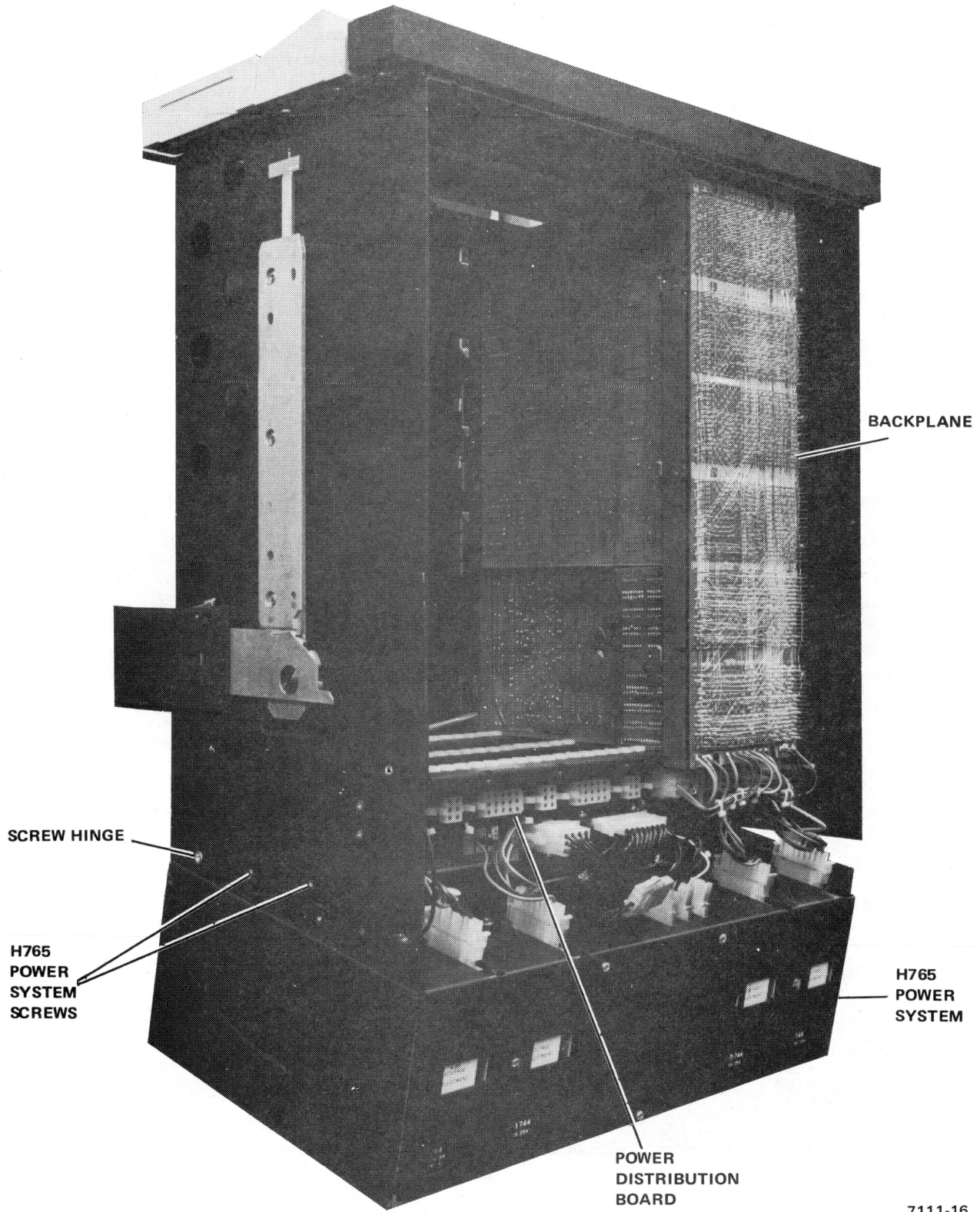

Figure 4-4 H765 Power System Access (Maintenance Position)

7111-16

4.4.3 H744, H745, and H754 Regulator Removal (Figure 4-5)

1. Perform the H765 power system access procedure (Paragraph 4.4.2).
2. Rotate the BA11-K 90 degrees.

CAUTION

Hold H765 in place while removing screws.

3. Tilt the H765 power system by removing two H765 power system screws on each side of the H765 (Figure 4-4).
4. Remove the bottom cover of the BA11-K.

WARNING

Power must be removed prior to removing regulators.

5. Disconnect the Mate-N-Lok from the regulator to be removed.
6. Remove three screws, two on the top and one on the bottom of the regulator (Figure 4-5).
7. Rotate the BA11-K 90 degrees to the horizontal position.

CAUTION

Use the correct length screws when installing regulator.

8. To remove regulator, slide it out.
9. Install new regulator per Paragraph 4.4.8.

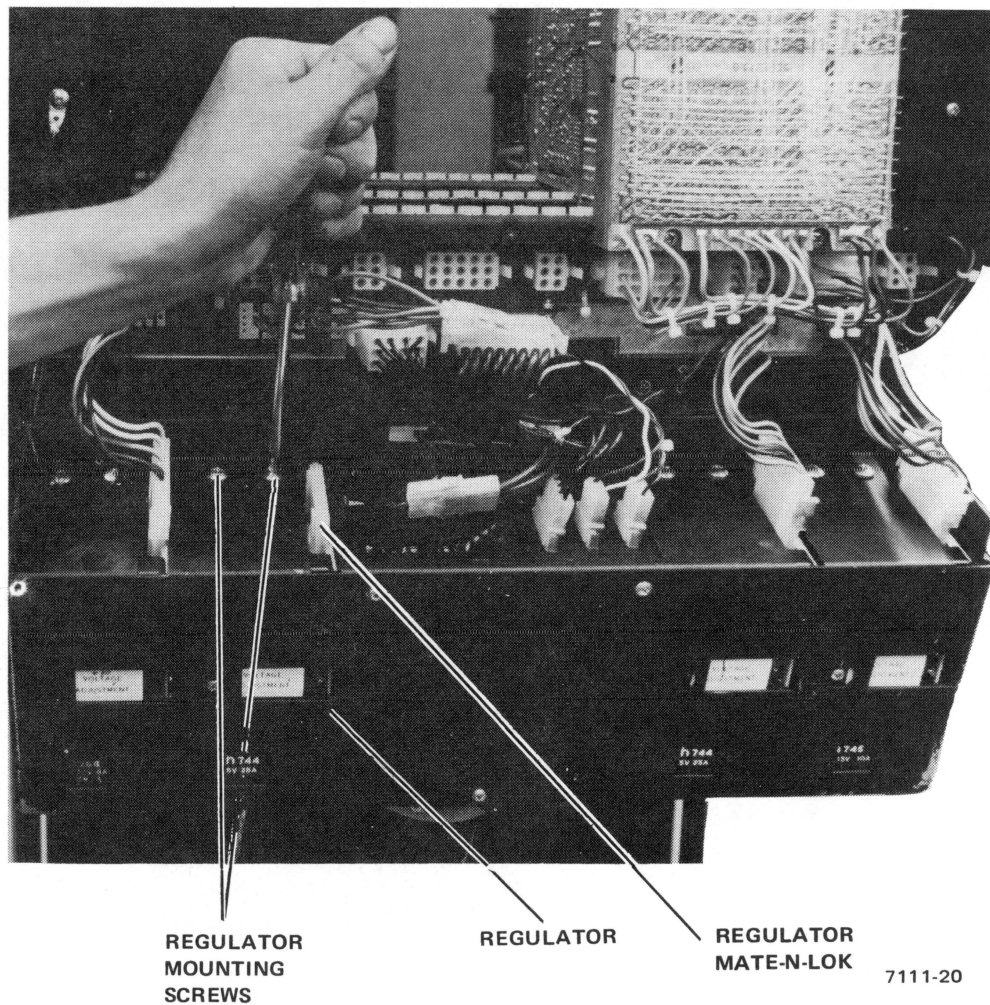

Figure 4-5 Regulator Removal

4.4.4 AC Input Box and 5411086 Regulator Removal

1. Perform the H765 power system access procedure (Paragraph 4.4.2).
2. Rotate the BA11-K 90 degrees.
3. Tilt the H765 power system by removing the two screws on each side of the H765 (Figure 4-4).

WARNING

Be sure that ac power is removed prior to removing the ac input box or 5411086 regulator.

4. Disconnect all the Mate-N-Loks connected to the front and back of the ac input box (Figure 4-6).
5. Disconnect the Mate-N-Loks from the 5411086 regulator.

CAUTION

Hold the ac input box in place while performing the next step.

6. Remove three screws and slide out the ac input box (Figure 4-6).
7. Remove 5411086 regulator from the ac input box.
8. Install a new regulator per Paragraph 4.4.8.

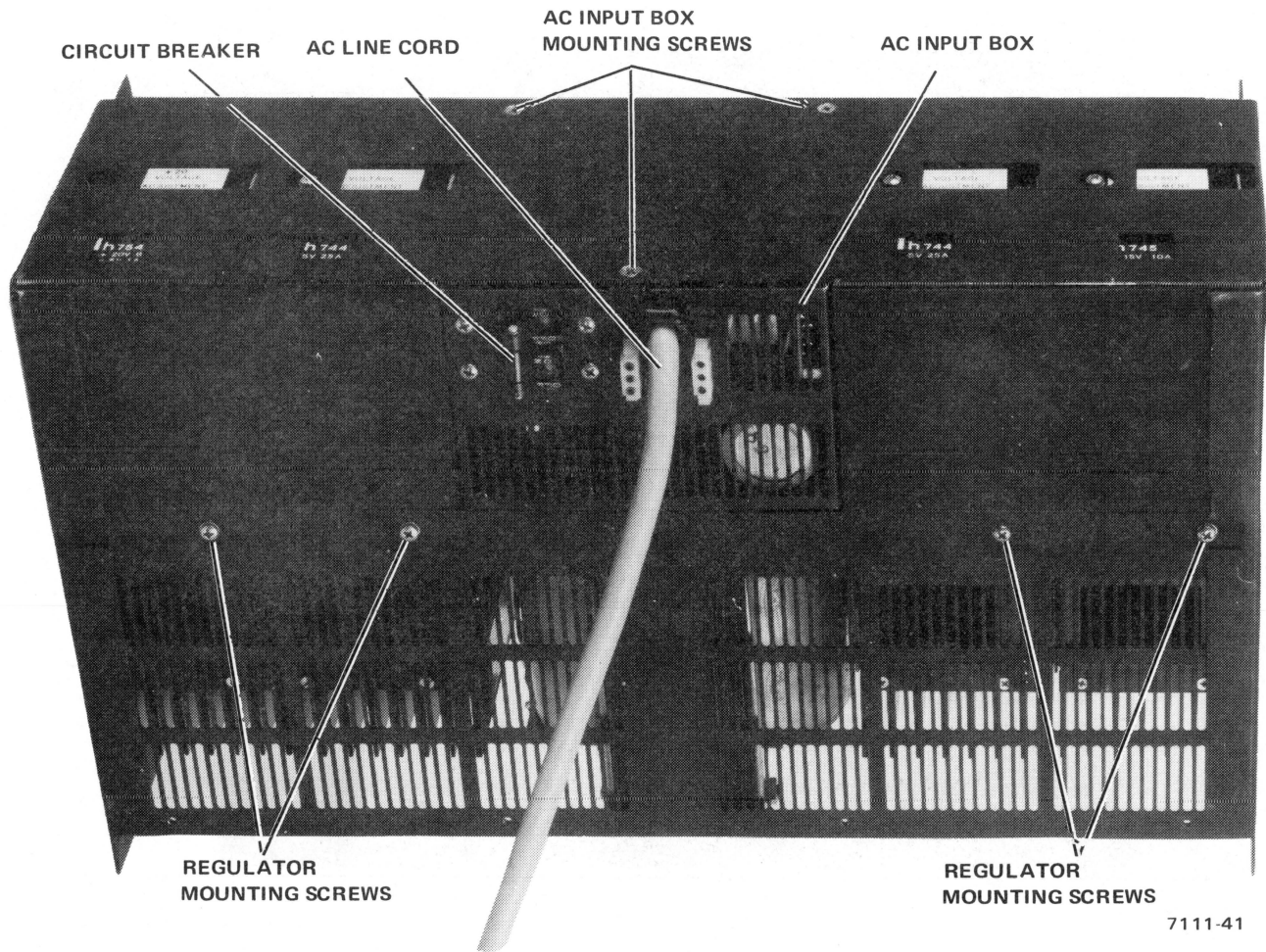

Figure 4-6 H765 Power System

4.4.5 Fan Removal

1. Perform the H765 power system access procedure (Paragraph 4.4.2).

NOTE

The BA11-K should be in a horizontal position when removing fans.

WARNING

Ensure ac power is removed prior to replacing fans.

2. Remove all modules.

3. On the module side of the fan, remove the two screws holding the fan (Figure 4-7).
4. Slide the fan up and out of the H765 and disconnect the jack from the fan, (1-1/2 in. fan).
5. For boxes with 2 in. fans, remove the power distribution board and slide the fan from the bottom of the box chassis.

CAUTION

When installing the fan do not tighten the screws beyond 10 in./lb. Tightening screws beyond 10 in./lb may cause the fan to bind.

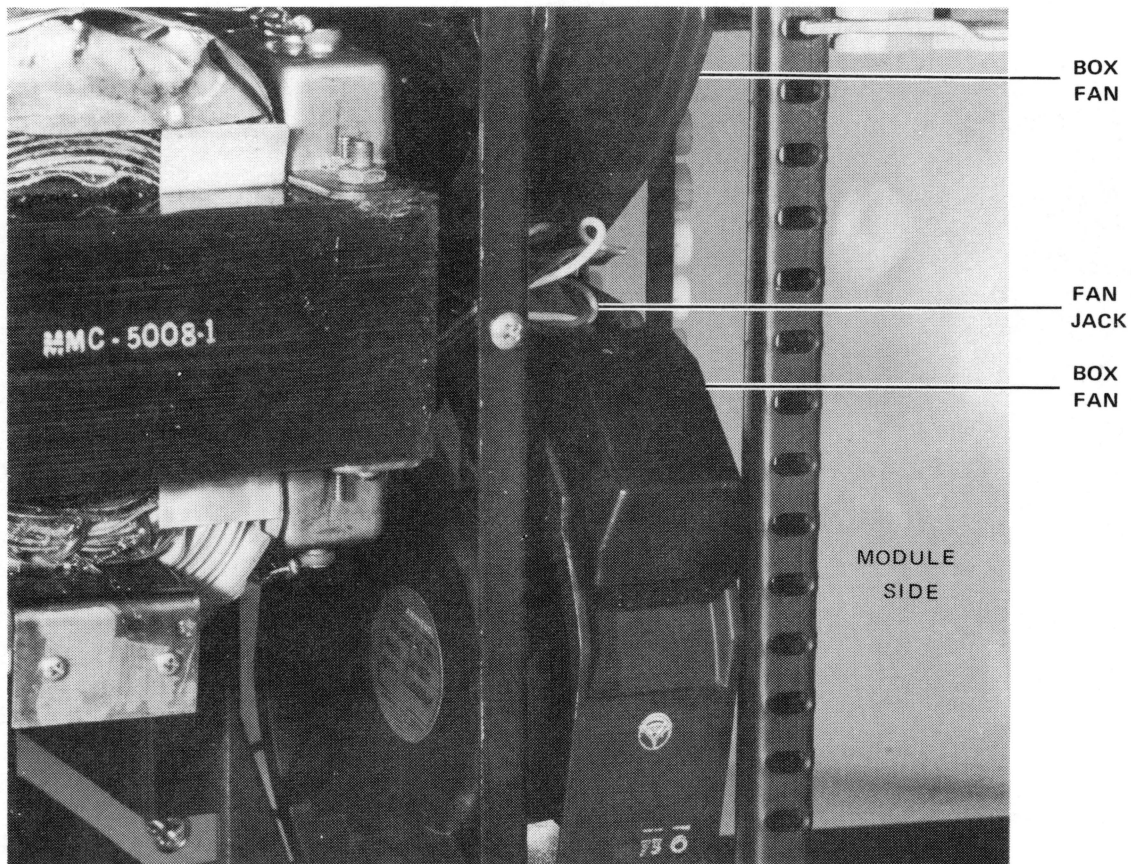

7111-6

Figure 4-7 Fan Removal

4.4.6 Transformer Assembly Removal

WARNING

Remove ac power before performing this procedure.

1. Remove the H745, H754, and both H744 regulators per Paragraph 4.4.3.
2. Remove the ac input box per Paragraph 4.4.4.
3. Remove both fans per Paragraph 4.4.5.
4. Disconnect the transformer assembly's Mate-N-Loks (Figure 4-8).
5. Remove both screws from the transformer assembly's cable clamp (Figure 4-9, sheet 2).
6. Rotate the BA11-K to the horizontal position.
7. Remove the transformer assembly's mounting screws and nuts (Figure 4-9, sheet 1) and lift out the transformer assembly.

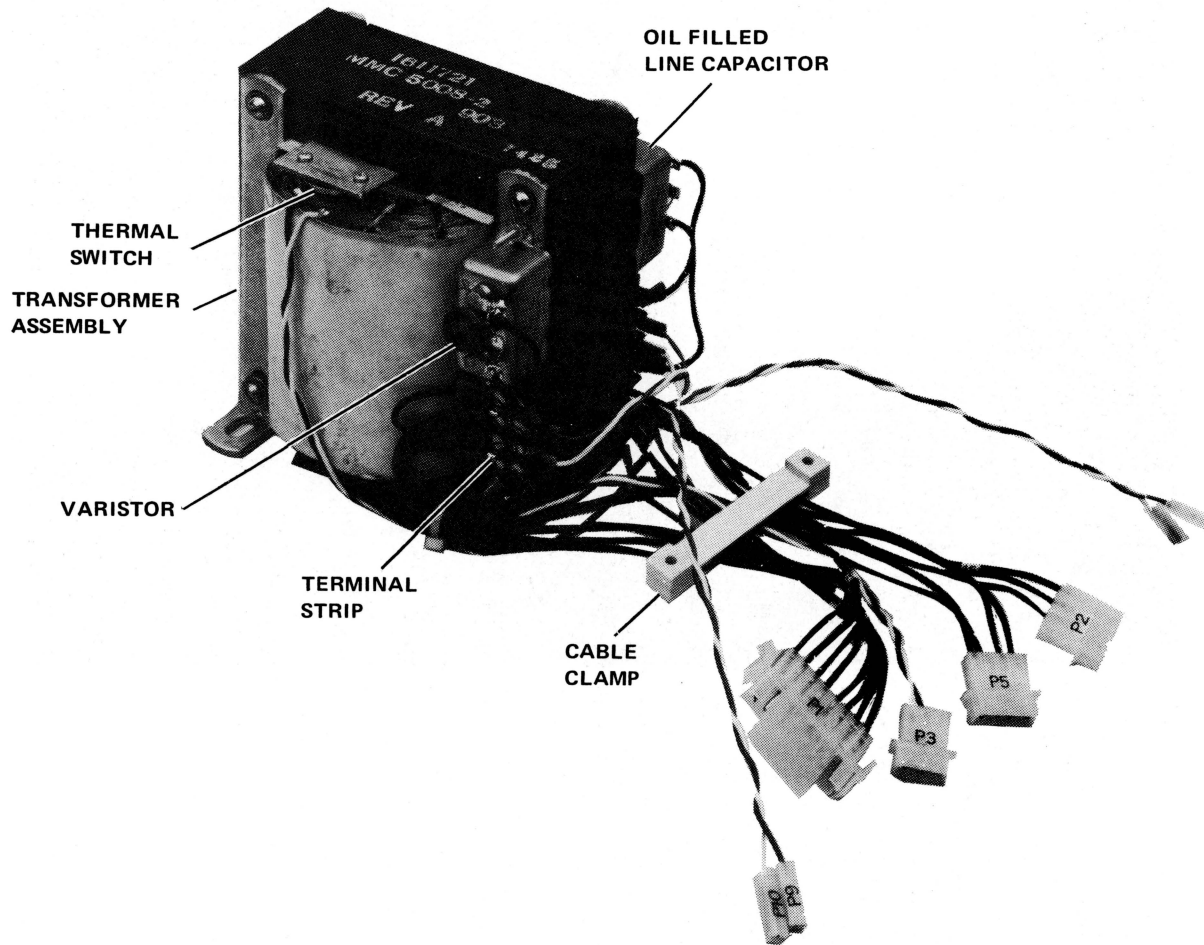

7111-4

Figure 4-8 Transformer Assembly

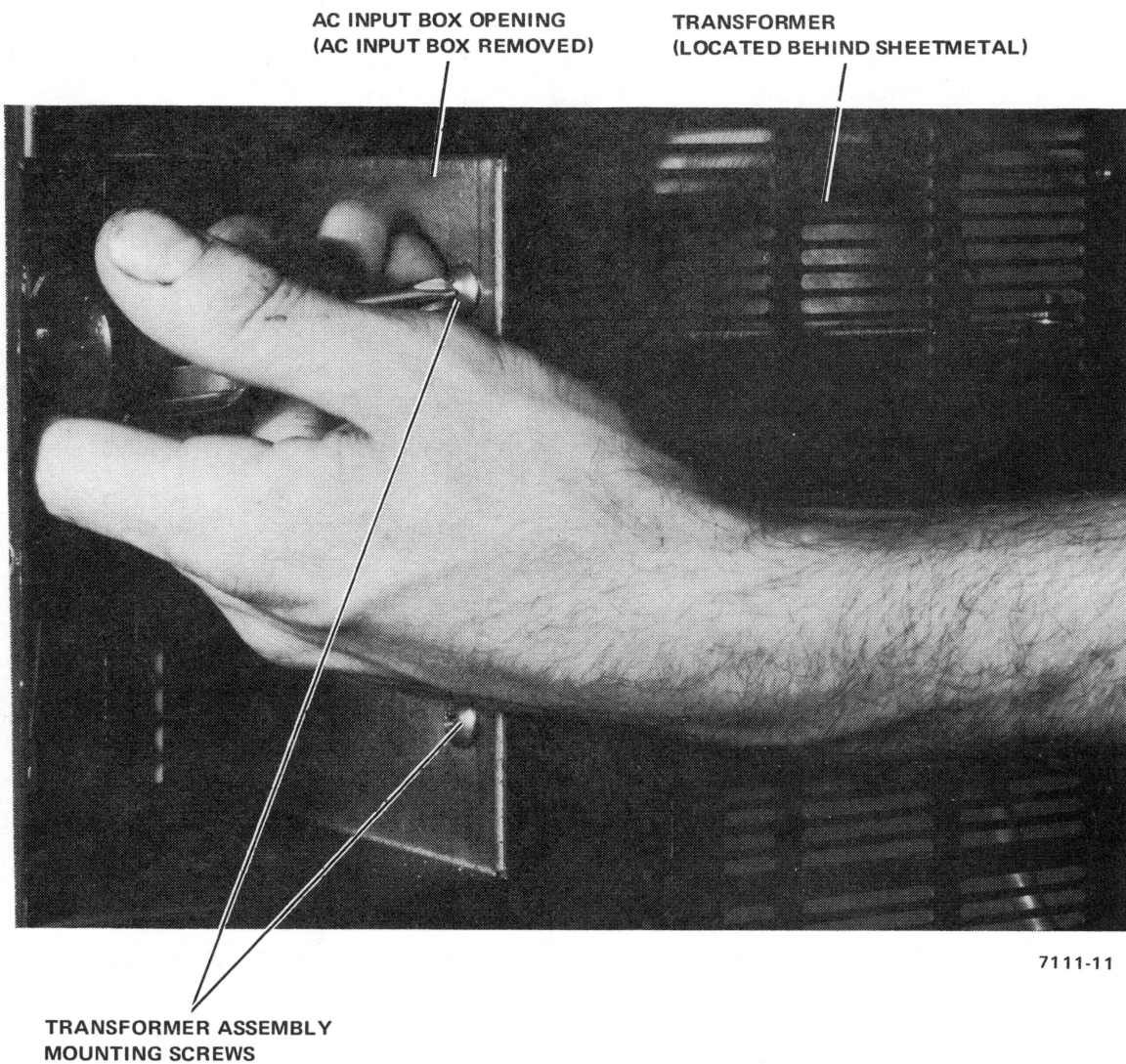
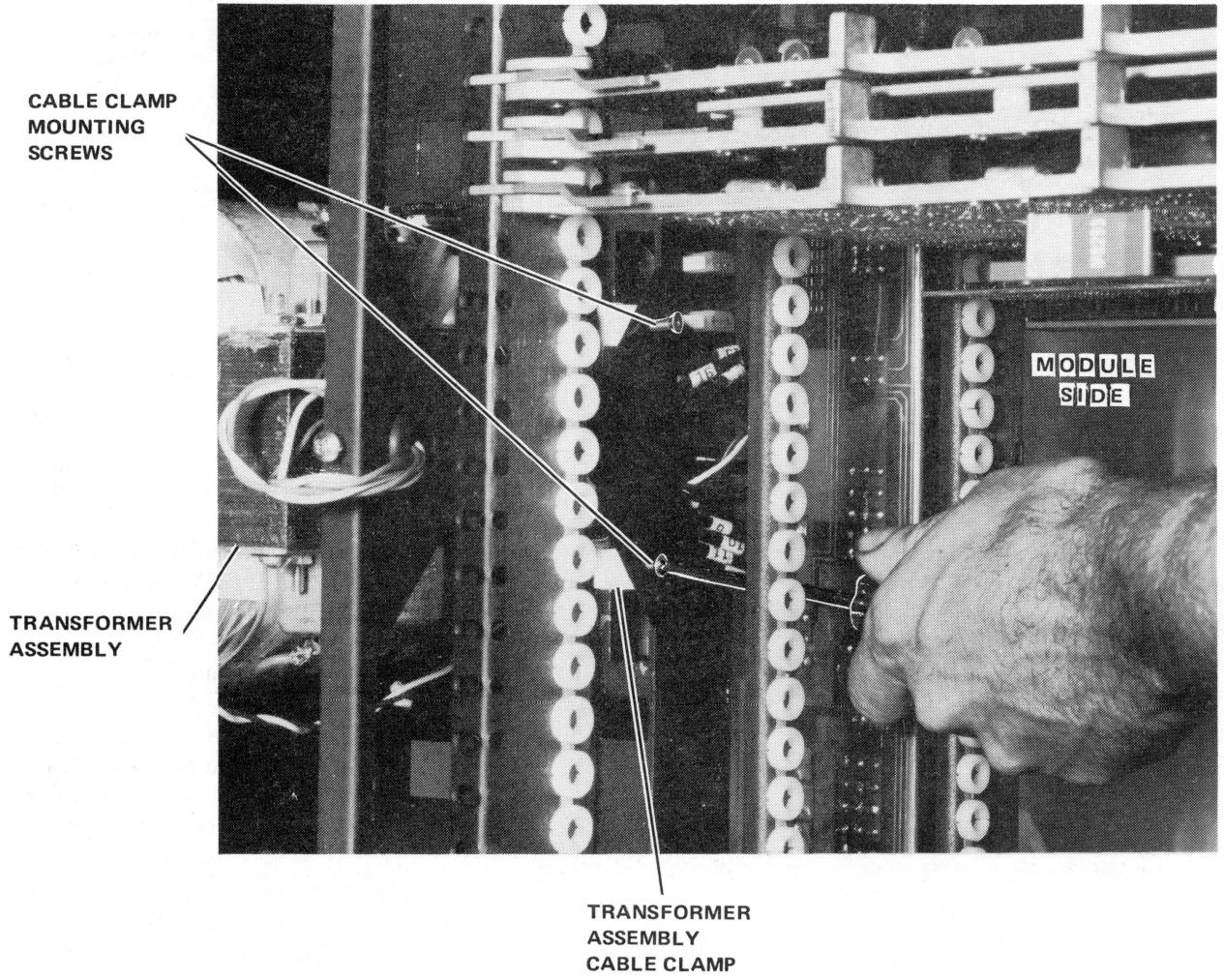

Figure 4-9 Transformer Assembly Removal (Sheet 1 of 2)



7111-10

Figure 4-9 Transformer Assembly Removal (Sheet 2 of 2)

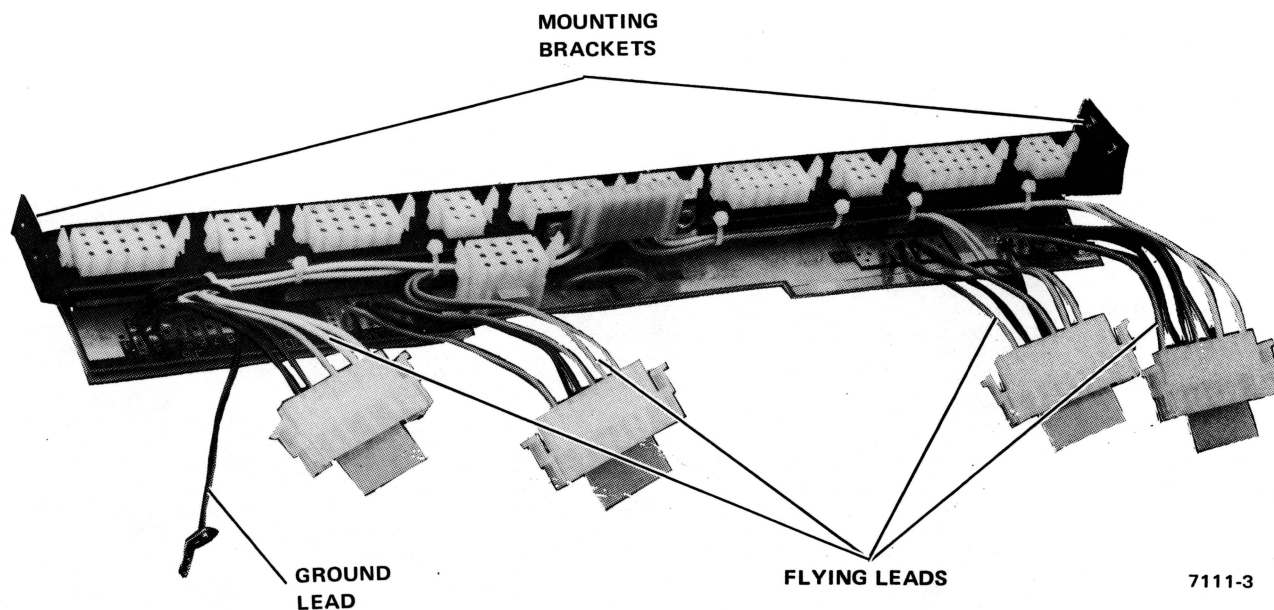

Figure 4-10 Power Distribution Board

4.4.7 Power Distribution Board Removal

WARNING

Remove ac power from the H765 power system.

1. Disconnect all Mate-N-Loks, ground leads, and console power wires from the power distribution board.
2. Remove the four screws from the mounting bracket (Figure 4-10) and remove the power distribution board.

4.4.8 Regulator Installation

1. Verify that power to H765 power system is off.
2. Install regulator.

3. Remove loads from regulator by disconnecting Mate-N-Loks J3, J5, J7, J9, and J11 on the power distribution board.
4. Turn on power to regulator.

NOTE

If regulator crowbars, turn power off and rotate regulator voltage. Adjust fully ccw (below crowbar voltage). Turn on power.

5. Using a DVM, measure voltage at power distribution board to ensure that voltage is within limits specified in Table 4-2. Adjust voltage if necessary.
6. Turn off power and reconnect Mate-N-Loks J3, J5, J7, J9, and J11 on power distribution board.
7. Turn on power and check regulator voltage at backplane per Table 4-2. Adjust voltage if necessary.

CHAPTER 5

UNPACKING AND INSTALLATION

5.1 INTRODUCTION

This chapter provides information on the unpacking and installation of the BA11-K mounting box. Information on installation certification is also included.

5.2 UNPACKING

The BA11-K is shipped ready to operate in a protective box (Figure 5-1). Remove the BA11-K from the box and visually inspect for damage. Save the shipping cartons and packaging materials in case it is necessary to return the BA11-K for service. The slide mounts are attached to the BA11-K, but the mounting screws are packed in a bag placed in the shipping container.

5.3 INSTALLATION IN A CABINET

Refer to Paragraph 2.7 for cabinet and slide mounting specifications. The front of the fixed slide has an integral bracket and is mounted in the cabinet with two screws that are secured with captive (Tinnerman) nuts. The rear of the fixed slide is attached to a separate L-shaped bracket with two screws and nuts. The bracket is attached to the cabinet with two screws that are secured with captive nuts. Mount the fixed slides equidistant from and parallel to the floor.

Lift the BA11-K and slide it carefully into the fixed guides until the slide release engages. Unlock the slide release and push the BA11-K fully into the cabinet. Extend the BA11-K enough to allow access to the front mounting screws. Slightly loosen the front and rear slide mounting

screws and slide the computer back and forth. This allows the slides to assume a position that causes minimum binding. Retighten the mounting screws.

5.4 AC POWER SUPPLY CONNECTION

5.4.1 Connecting to 115 Vac or 230 Vac

The BA11-KE/KF, designed for use on 115 Vac/230 Vac circuits, is equipped with a three-prong connector, which, when inserted into a properly wired 115 Vac or 230 Vac outlet, grounds the chassis. It is unsafe to operate the BA11-K unless the chassis is grounded, since normal leakage current from the power supply flows into metal parts of the chassis.

If the integrity of the ground circuit is questionable, the user is advised to measure the potential between the computer case and a known ground with an ac voltmeter.

The BA11-KE/KF operates at voltages ranging from 90 V to 132 V/180 V to 264 V (47 Hz–63 Hz). The plug configuration and specifications are shown in Figure 5-2.

For installations outside of the United States or where the National Electric Code does not govern building wiring, the user is advised to proceed with caution.

5.4.2 Quality of AC Power Source

If the BA11-K is to be installed in an electrically noisy environment, it may be necessary to condition the ac power line. Digital Field Service engineers can assist customers in determining if their ac line is satisfactory.

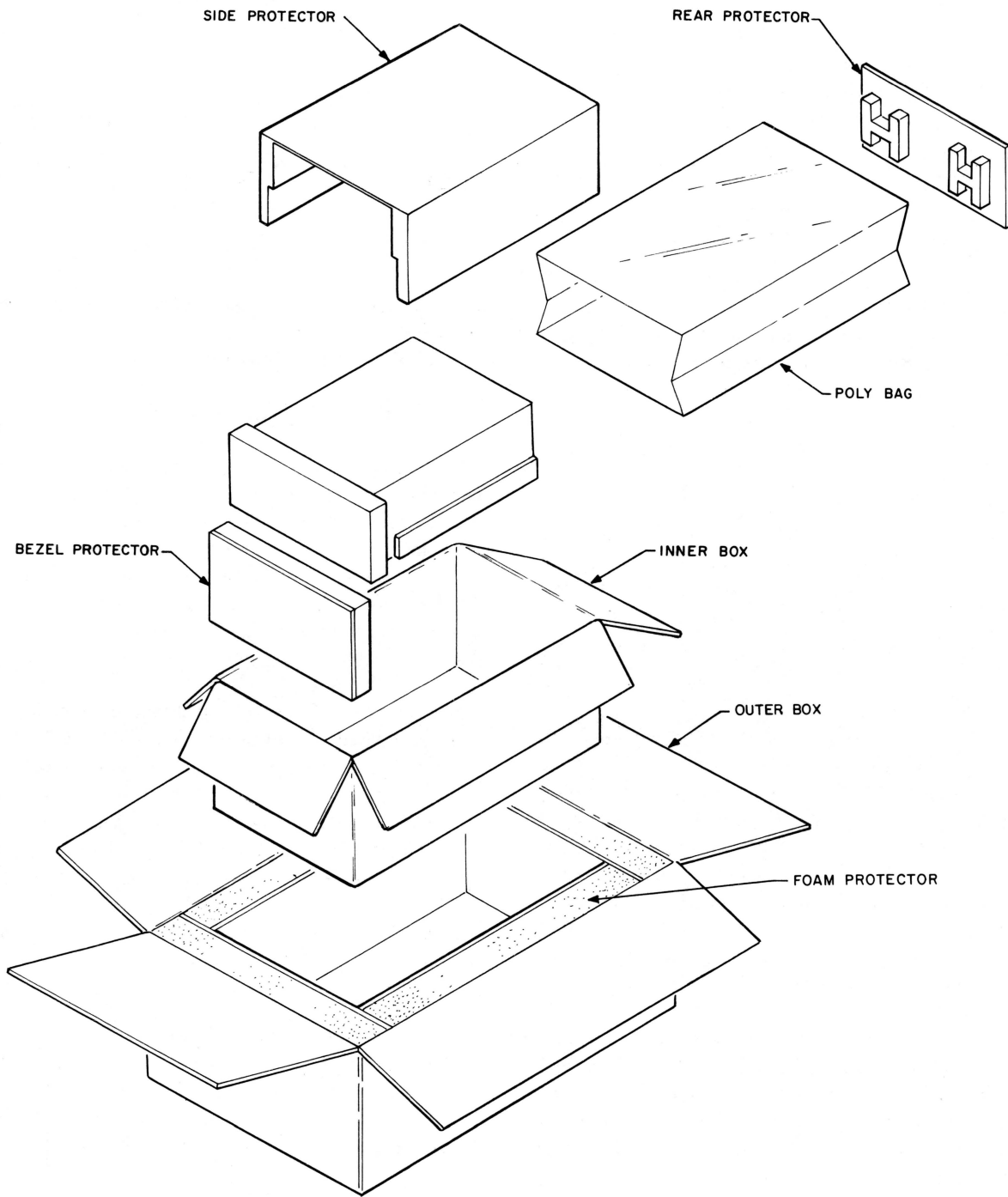

11-2569

Figure 5-1 BA11-K Packaging

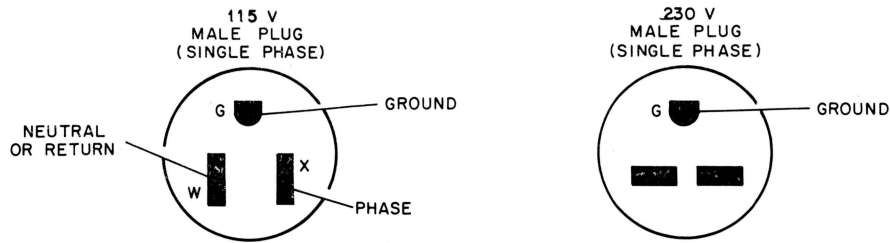

CONNECTOR SPECIFICATIONS

DESCRIPTION	NEMA * CONFIGURATION	POLES	WIRES	PLUG	RECEPTACLE
				DEC PART NO.	DEC PART NO.
115V, 15 AMP	5-15	2	3	90-08938	12-05351
230V, 15 AMP	6-15	2	3	90-08853	12-11204

* ADD P SUFFIX FOR PLUG
ADD R SUFFIX FOR RECEPTACLE

11-2572

Figure 5-2 Connector Specifications

5.5 REMOTE POWER CONTROL

Power control (Figure 5-3) of the BA11-K can be accomplished by the following three methods:

1. A key switch can be utilized to control the BA11-K. This is accomplished by connecting the proper cable to J2 or J3 on the ac input box.
2. Mate-N-Loks J1, J2, or J3 on the ac input box can be configured to enable a power controller to control application of ac power.
3. CB1 on the ac input box can be used as an on/off switch, only if pins 1 and 3 of J3 are shorted together.

5.6 INSTALLATION CERTIFICATION

Once the BA11-K has been installed, it is strongly recommended that a system diagnostic be run to ensure that the equipment operates correctly and that installation has been properly performed. Because system configurations vary widely, no one diagnostic will completely exercise all the attached devices.

The user's manual that comes with the diagnostic package should be consulted for the appropriate diagnostic to be

run. The user's manual lists the devices that each diagnostic will exercise. Once the diagnostic is selected, the respective diagnostic write-up should be consulted for specific operating instructions. If the user is not familiar with console operation and/or procedures for loading paper tapes, he or she should read the applicable manual.

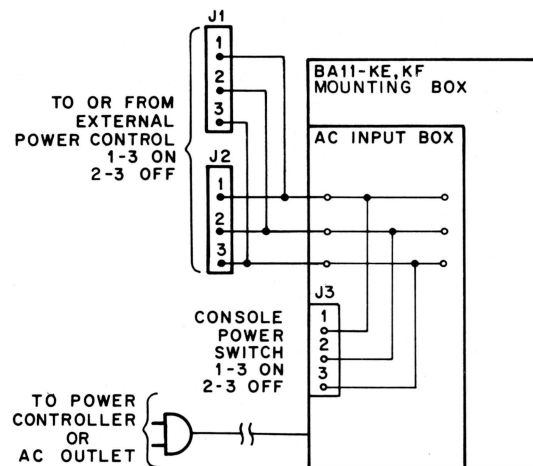

11-2563

Figure 5-3 Power Control

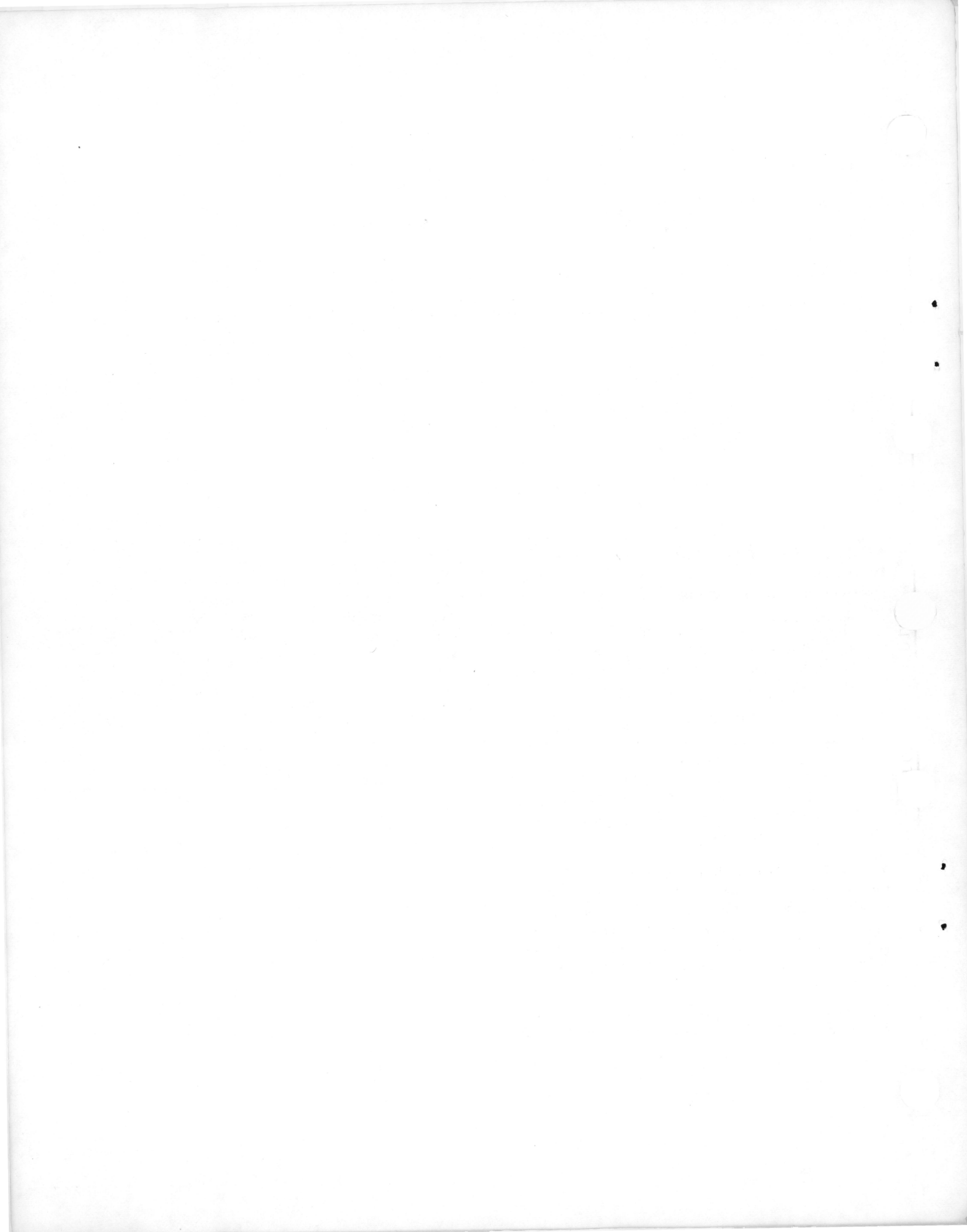

Your comments and suggestions will help us in our continuous effort to improve the quality and usefulness of our publications.

What is your general reaction to this manual? In your judgment is it complete, accurate, well organized, well written, etc.? Is it easy to use? _____

What features are most useful? _____

What faults do you find with the manual? _____

Does this manual satisfy the need you think it was intended to satisfy? _____

Does it satisfy *your* needs? _____ Why? _____

Would you please indicate any factual errors you have found. _____

Please describe your position. _____

Name _____ Organization _____

Street _____ Department _____

City _____ State _____ Zip or Country _____

OUT ON DOTTED L.

Fold Here -----

Do Not Tear - Fold Here and Staple -----

**FIRST CLASS
PERMIT NO. 33
MAYNARD, MASS.**

**BUSINESS REPLY MAIL
NO POSTAGE STAMP NECESSARY IF MAILED IN THE UNITED STATES**

Postage will be paid by:

Digital Equipment Corporation
Technical Documentation Department
146 Main Street
Maynard, Massachusetts 01754

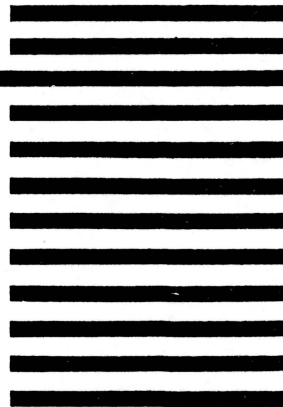

pdp11

**BA11-K mounting box
manual**

digital